

**KEENCUT**

# OVAL 6

® INSTRUCTION MANUAL

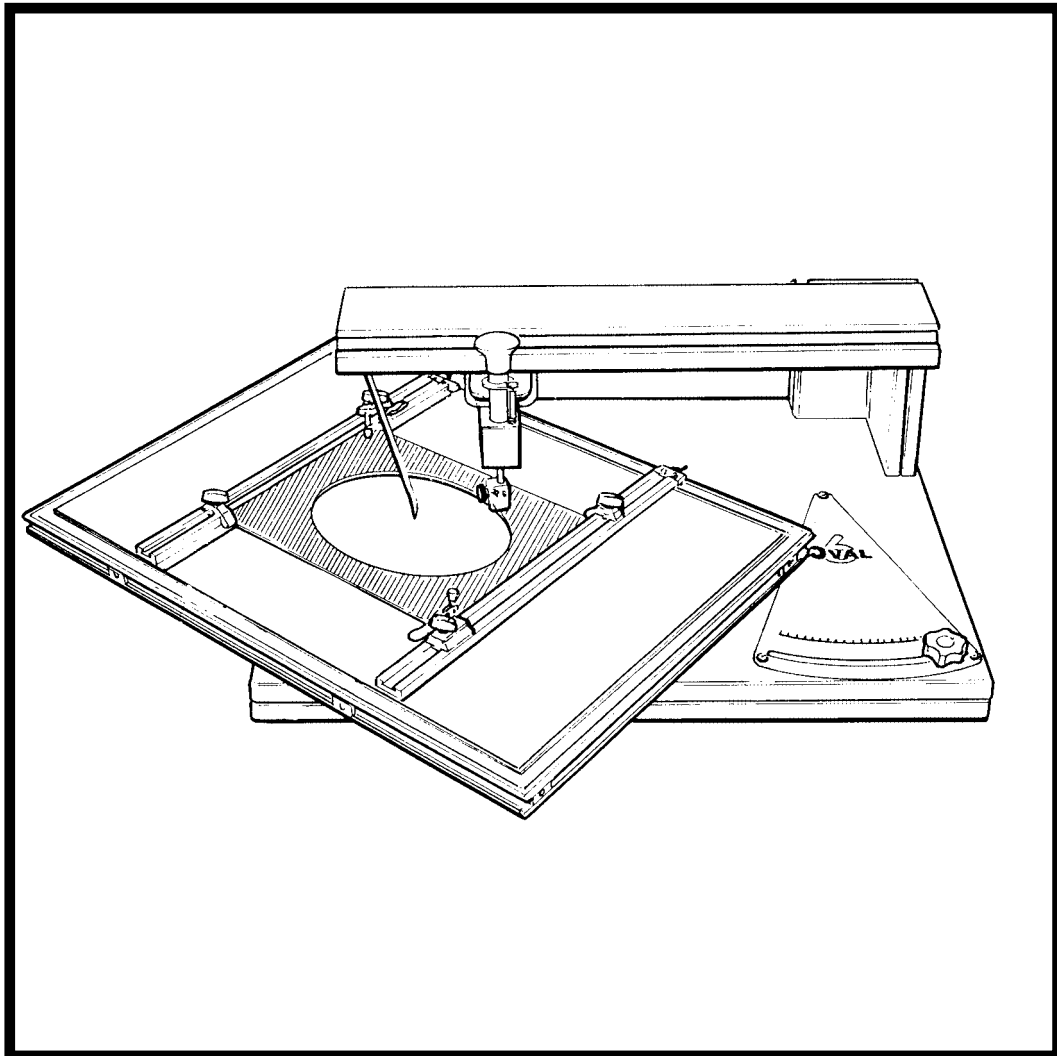

**KEENCUT**

*Keencut - the world's finest cutting machines*

## 2 Packing list

- 2.1 Unpacking your machine

## 3 Assembly

- 3.1 Fitting the Beam and Cutting Head
- 3.2 Fitting the Turntable
- 3.3 Fitting the Clamp Bars

## 4 Operation

- 4.1 Setting the size of the oval/circle
- 4.2 Setting the blade depth and using the Clamps
- 4.3 Cutting an oval/circle
- 4.4 Calibrating the Scales
- 4.5 The Centre Pointer
- 4.6 Cutting small ovals and circles

## 5 The Craftsman Toolset (optional)

- 5.1 Embossing
- 5.2 Penlining
- 5.3 Cutting V-grooves
- 5.4 Cutting glass ovals/circles
- 5.5 Cutting glass ovals/circles (Cont'd)

## 6 Looking After Your Oval 6

- 6.1 Maintenance & Blades

### Introduction

Thank you for choosing a Keencut Oval 6. Every effort has been made to bring you a superbly built product with the promise of many years of good service. Please read these instructions carefully in order to obtain maximum benefit from your machine and remember, in case of difficulties ask your distributor or Keencut Limited for assistance.

Once familiar with the many functions of the Oval 6 and the advantages of the unique turntable system, your own creativity will enable you to produce very satisfying and individual work that is the hallmark of the successful framer.

---

# 2.1 Unpacking your Machine

# 2.1

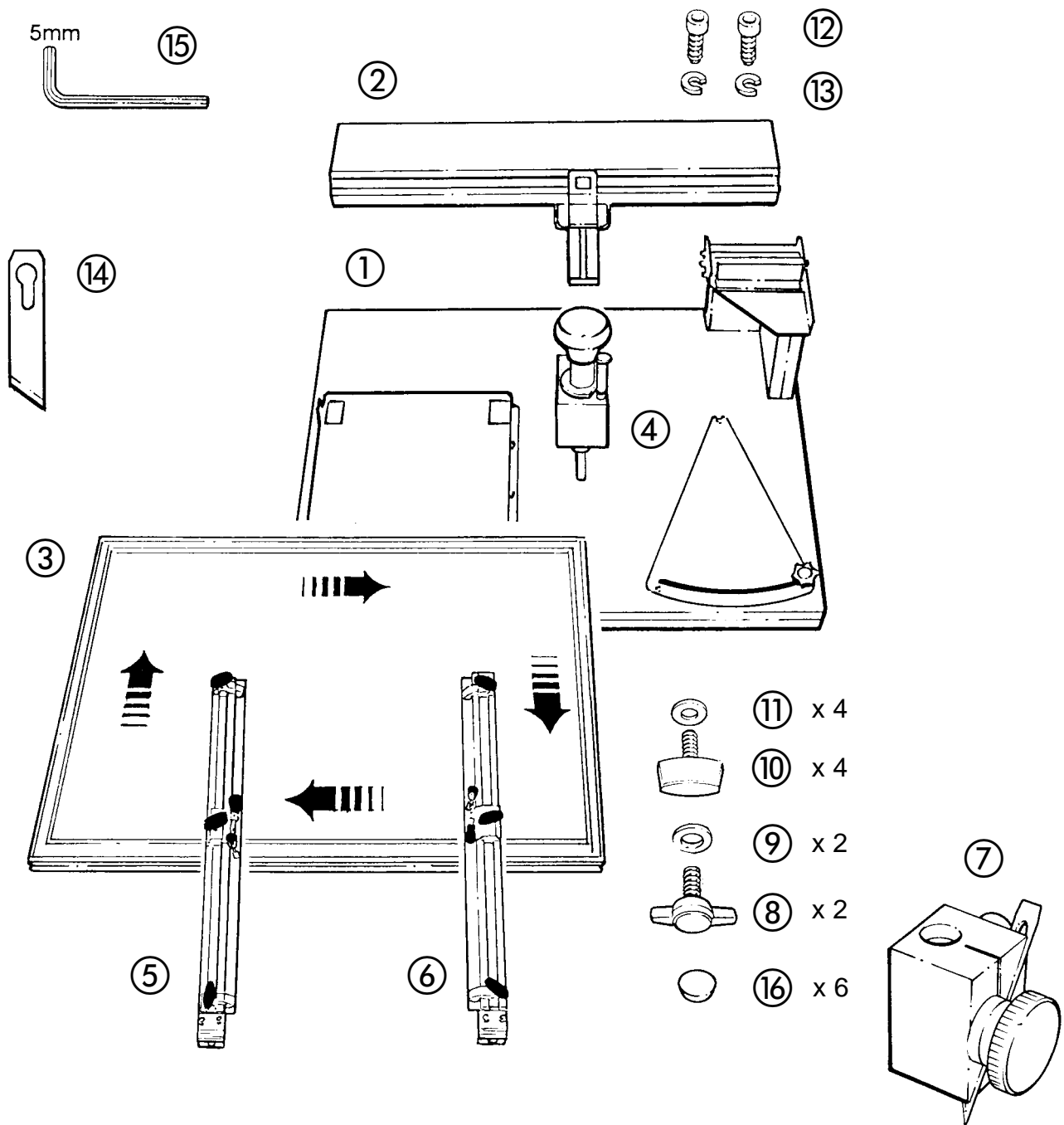

- |    |                             |     |                      |
|----|-----------------------------|-----|----------------------|
| 1. | Main Base                   | 9.  | M8 washer x 2        |
| 2. | Beam                        | 10. | M6 thumbscrew x 4    |
| 3. | Turntable                   | 11. | M6 washer x 4        |
| 4. | Cutting Head                | 12. | M6 screws x 2        |
| 5. | LH clamp bar                | 13. | M6 spring washer x 2 |
| 6. | RH clamp bar                | 14. | Blades               |
| 7. | Bevel/vertical blade holder | 15. | 5mm Hexagon wrench   |
| 8. | M8 thumbscrew x 2           | 16. | Plastic feet x 6     |

### Fitting the Beam and Cutting Head

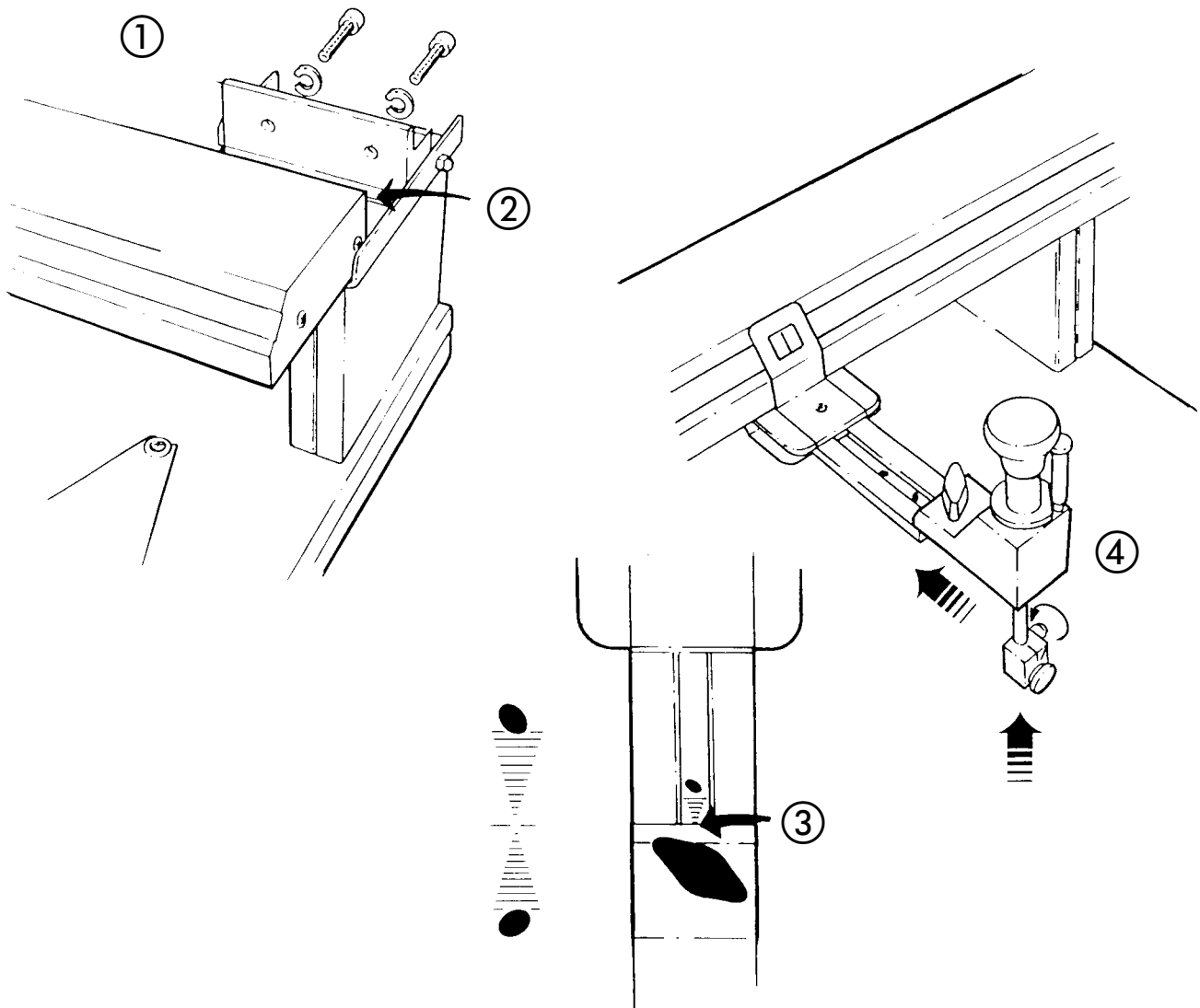

**NOTE:** Do not carry the machine by the Turntable or Beam.

1. Attach the Beam to the hinge of the Main Base using the two M6 screws and spring washers.
2. Ensure precise alignment of the Beam by positioning it carefully on the small ledge of the hinge.  
Tighten the two socket screws firmly using the 5mm hexagon wrench.
3. Fit the Cutting Head to the Beam by sliding it onto the bracket until the edge of the aluminium block aligns with the centre of the 'Lazy oval scale' as shown.  
Tighten the thumbscrew.
4. Fit the Blade Holder to the shaft on the Cutting Head and fasten it by tightening the black plastic thumbscrew.

The machine is now set to cut ovals 10cm and larger. For smaller ovals see '4.6'.

### Fitting the Turntable

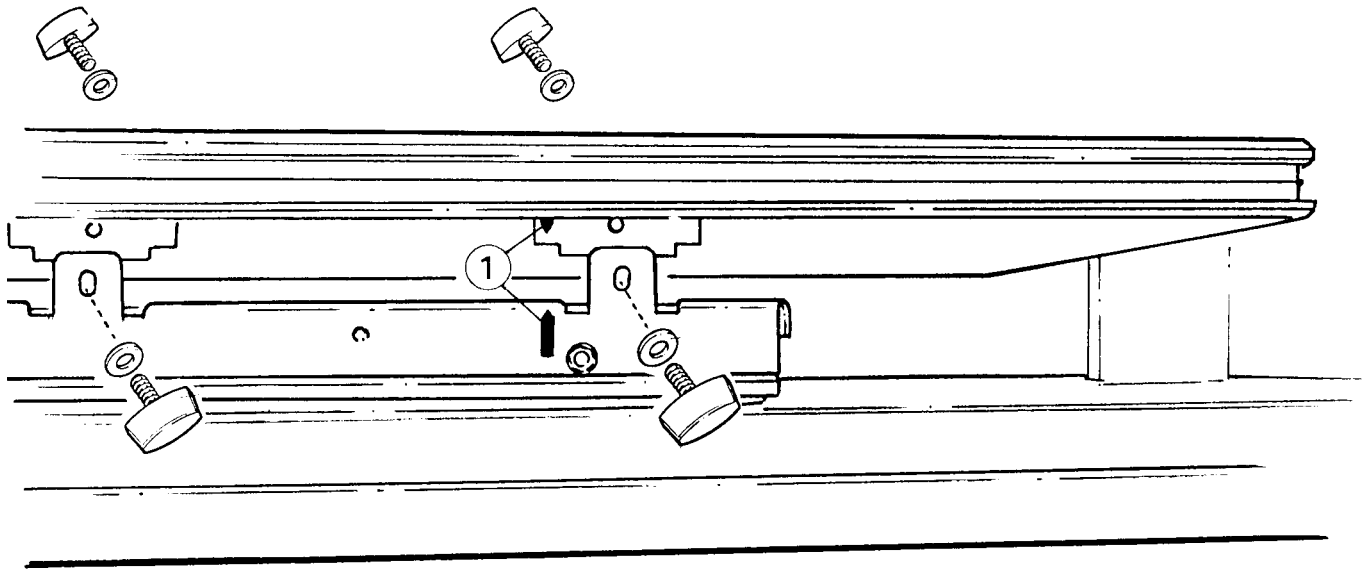

1. Line up the red arrow under the Turntable with the red arrow on the Main Base.
2. Place the Turntable with its four tabs inside the tabs of the Main Base and slide the Turntable from left to right, the tabs will drop into alignment preventing the Turntable sliding further.
3. Fit and tighten the four M6 thumbscrews and washers.

**NOTE:** The optional MAXI Turntable attaches in the same way as the standard Turntable.

**When cutting on the Oval 6 the blade tip runs on a sheet of glass this is not supplied with the machine.** Cutting on to a glass surface is the most safe, reliable and economical method. A "self healing mat" can be used but the surface will deteriorate rapidly when bevel cutting. A matboard cutting mat will quickly be destroyed and will allow the blade to penetrate and damage the printed grid below.

**CAUTION: USE EYE PROTECTION WHEN CUTTING GLASS**

Cut a sheet of **3mm ( 1/8" )** glass to the following size: **(do not use 2mm glass)**

Table type	Size - metric	Size - imperial
Standard	453 x 642mm	17 <sup>13</sup> / <sub>16</sub> " x 25 <sup>1</sup> / <sub>4</sub> "
Maxi	642 x 802mm	25 <sup>1</sup> / <sub>4</sub> " x 31 <sup>9</sup> / <sub>16</sub> "

There is no need to polish the edges. Place the glass in the recess of the Turntable on the printed grid.

### Fitting the Clamp Bars

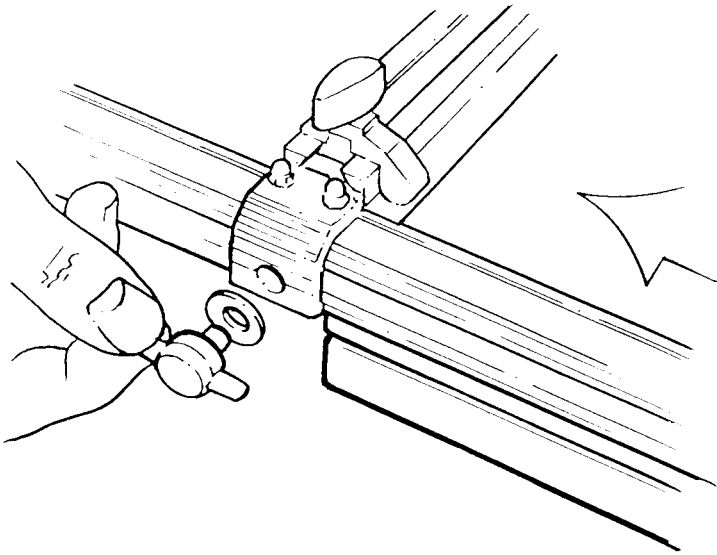
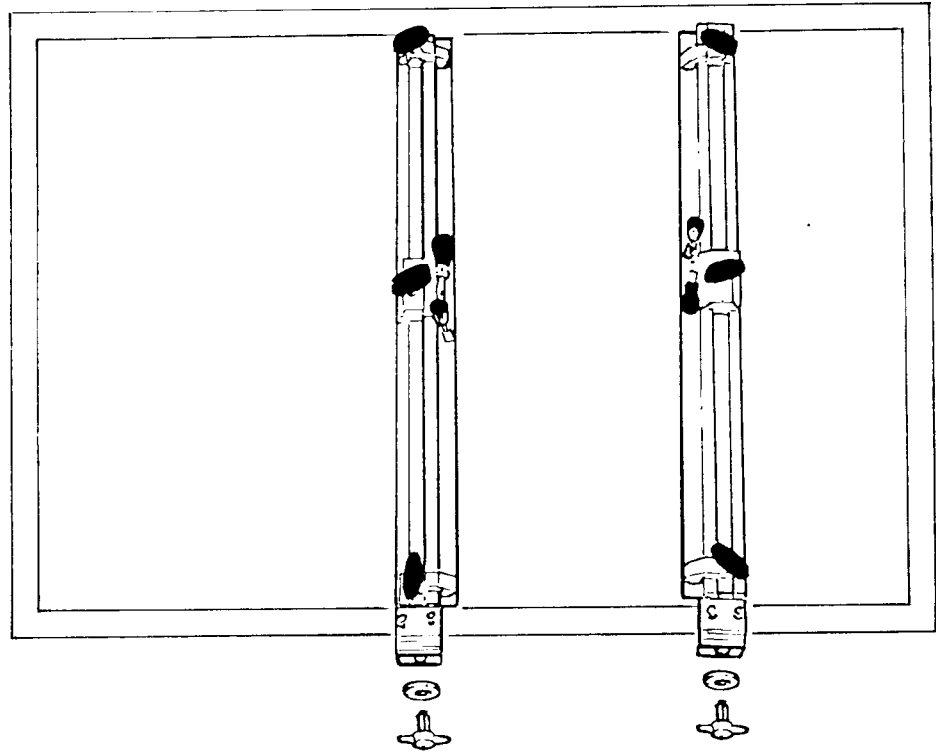

1. Find the two Sliding Nuts in one of the long edges of the Table.
2. Fit the two Clampbars to the Turntable using the M8 thumb screws and washers.

### Setting the size of the Oval/Circle

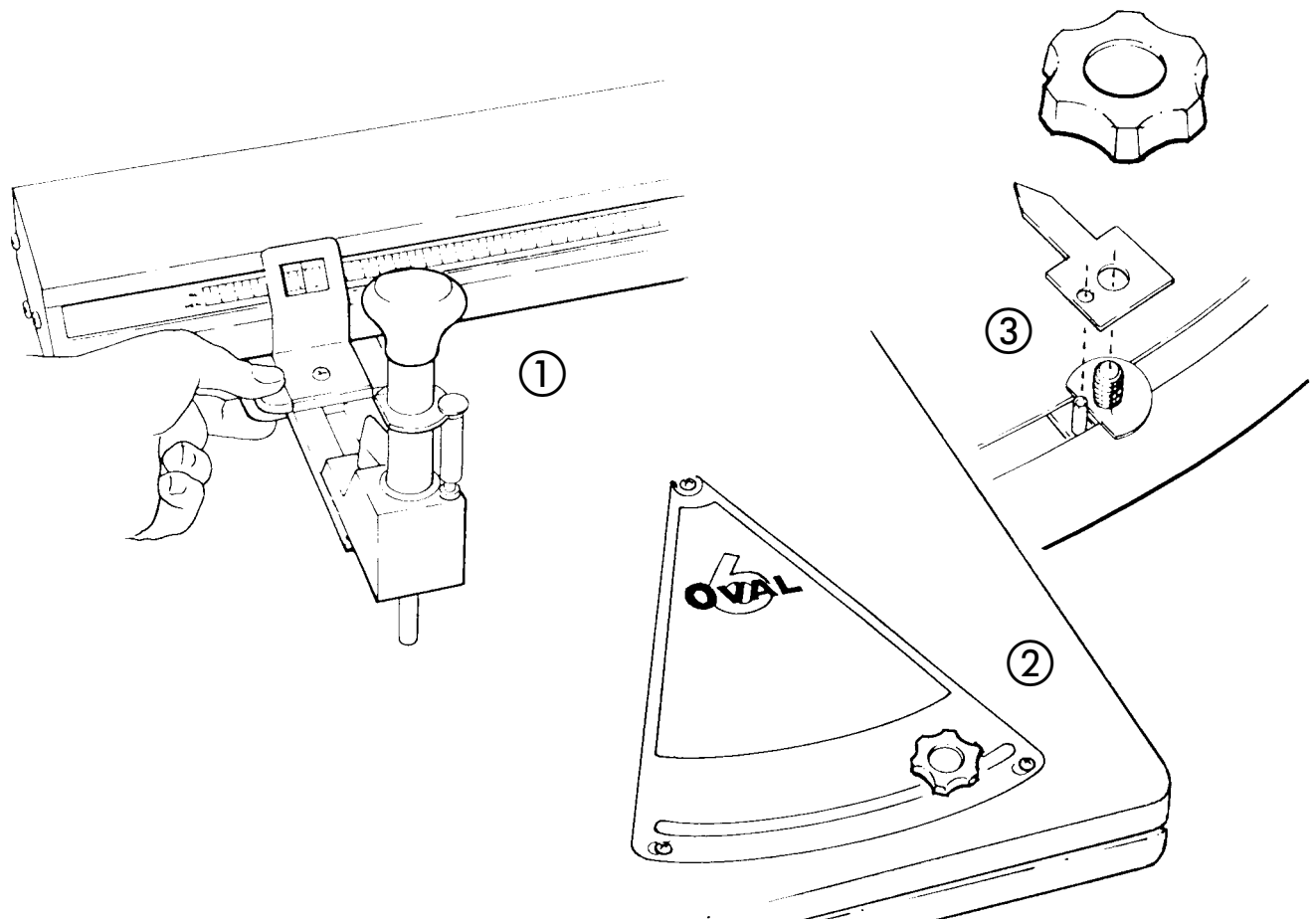

There are two scales that require setting dependant upon the size of the oval/circle:

1. The **width** of the oval (or diameter of the circle) is set on the beam scale by squeezing the release lever and cutter head support then sliding the cutter until the red line in the window indicates the required dimension. The scale can be read in inches or centimetres.

<b>Scale tightening</b>	If the measuring scale itself slides too easily set the cutting head to 10 (cms. or ins.), slide the scale from its groove by about 10cm [4"] and twist it to lightly distort the strip. Replace the scale and check the friction, slide the scale to again read 10.
-------------------------	----------------------------------------------------------------------------------------------------------------------------------------------------------------------------------------------------------------------------------------------------------------------

2. The **difference** between the width and length of the oval is set on the differential scale, turn the knob counter-clockwise by half a turn to release and set to the required dimension, lock in position. For a circle set the pointer as far to the right as it will go (not necessarily the 'zero' on the scale). The scale will be set to either inches or centimetres and can be changed by turning the scale over as follows:
3. Set the scale to zero and remove the two screws then remove the knob and pointer. Turn the scale over and carefully refit the pointer ensuring the small pin is located in the hole (as shown), refit the knob and loosely refit the two screws. Adjust the scale so that it reads zero then moderately tighten the two screws.

If you find the machine does not cut accurately the scales require calibrating – refer to the next section.

### Setting blade depth and using the clamps

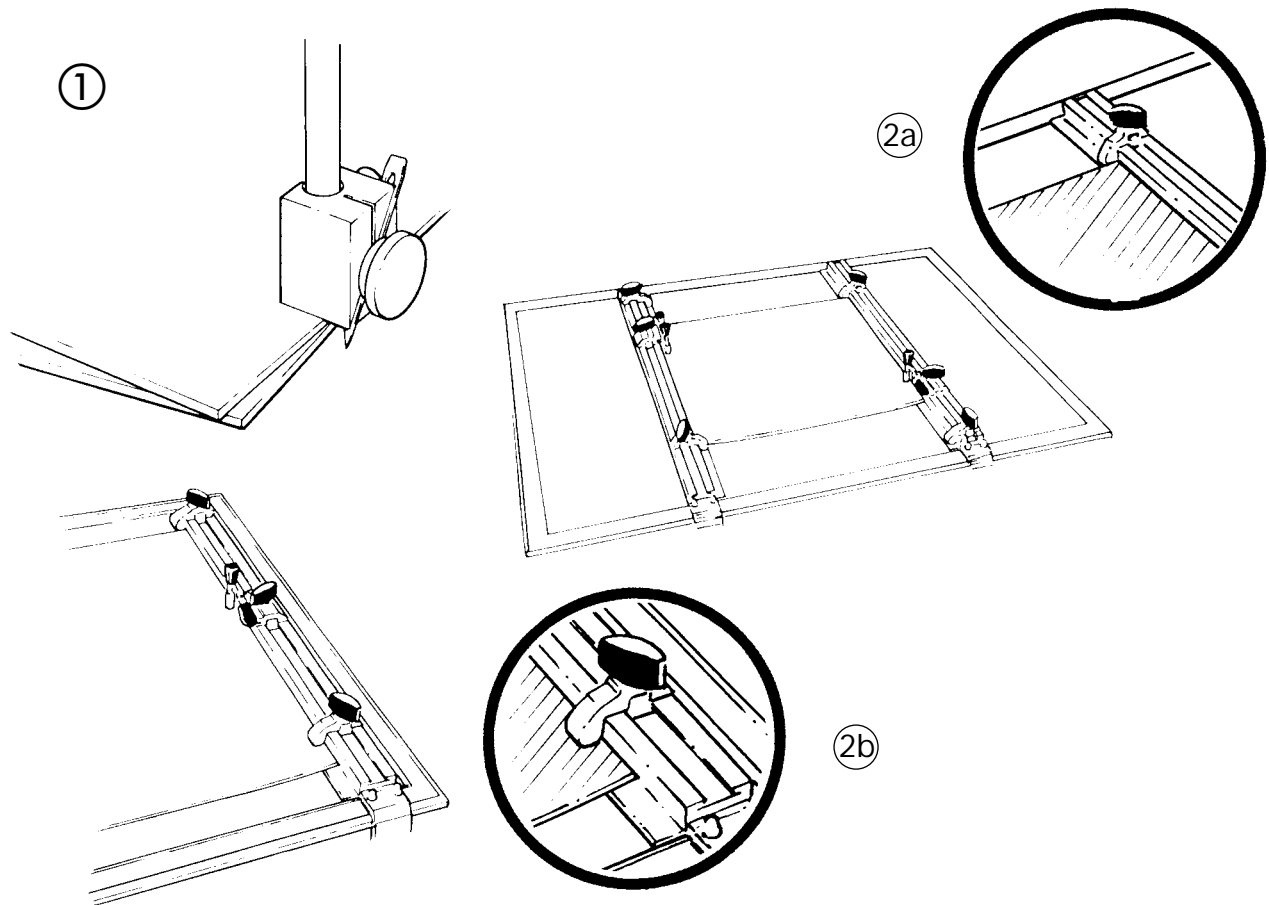

#### 1. Setting the blade depth

The blade should be set deep enough to penetrate the board being cut with a clearance of approximately 1.5mm [ $1/16$ "] under the blade holder (thickness of regular matboard).

- a. Loosen the blade clamping knob and remove the old blade.
- b. Place two thicknesses of matboard together on the turntable.
- c. Lower the blade holder (by rotating the cutting head knob) leaving the blade slots clear.
- d. Fit the blade in the slot allowing it to drop so the tip touches the turntable and tighten the blade.

**NOTE:** If the material being cut is thicker than regular matboard use a piece of the material for the depth of cut and a piece of regular matboard to set the clearance.

#### 2. The clamping system

The clamping system consists of two clamp bars each with two corner stops and a toggle clamp. For small and medium size mats only two of the corner stops positioned diagonally opposite are normally required (fig. 2a). For larger mats use all four corner stops, for extra security the corner stops can be used as additional clamps (fig. 2b.). The toggle clamps are adjustable to take different thicknesses of board, turn the black rubber cap to adjust.

The scales on the turntable frame and the clamp bars are all set so that the 'zero' indicates the centre of rotation of the table. So, if a mat is centred in the clamps according to the scales the oval will be produced in the centre of the mat.

### Cutting an Oval/Circle

#### Bevel cutting

The following refers to cutting a 14 x 10 oval centrally in a matboard 20 x 16 (cms. or ins.)

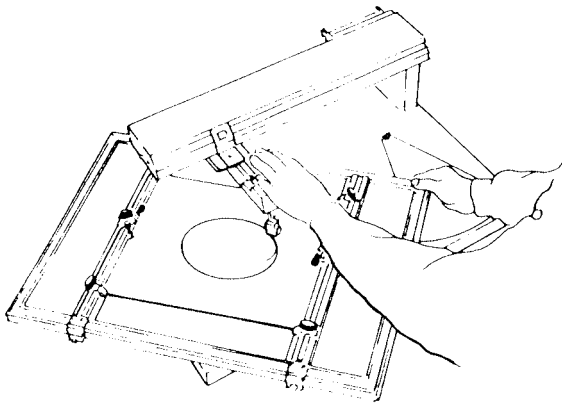
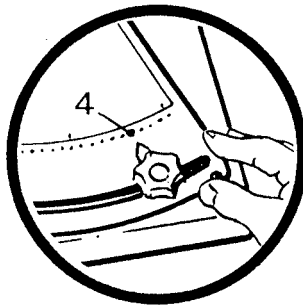
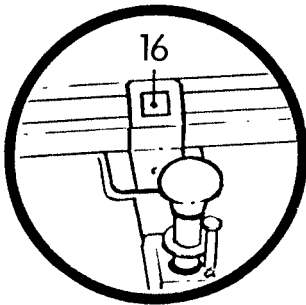
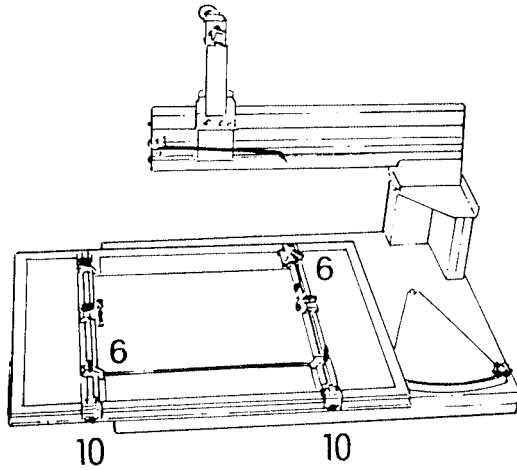

1. Lift and park the beam to give easy access to the turntable.
2. Set the two clamp bars to 10 either side of the zero point on the table edge scale. Set the corner stops to 6 on the clamp bars. Position the matboard coloured face up and clamp in place using the toggle clamps.
3. Lower the beam. Set the width scale to 16 and the differential scale to 4 ( $20-16 = 4$ ). Twist and lower the cutting head so the blade rests on the eventual fallout.
4. Do not touch the cutting head knob yet and rotate the turntable for approximately  $\frac{1}{4}$  of a turn to align the blade.
5. Keep turning and smoothly apply finger pressure to the top of the cutting head knob, continue turning until the fallout moves. Raise and twist the knob to park the cutting head.

**NOTE:** If the size of the oval does not reflect the sizes set refer to the next section on 'Calibrating the scales'

#### Vertical cutting

The vertical blade is of the same type as that used for bevel cutting (SM02 or SM03 for small oval/circles) but held in a different slot in the blade holder. The blade depth is not as critical but should be long enough to cut through the material without the base of the blade holder touching the surface of the matboard and not so far extended that the blade tip bends when cutting.

Use the same procedure as explained above, a cleaner cut will be produced by placing the matboard in the machine coloured face down as the thickness of the vertical blade can displace the edges of the cut upwards producing a small burr on the coloured edge.

### Calibrating the scales

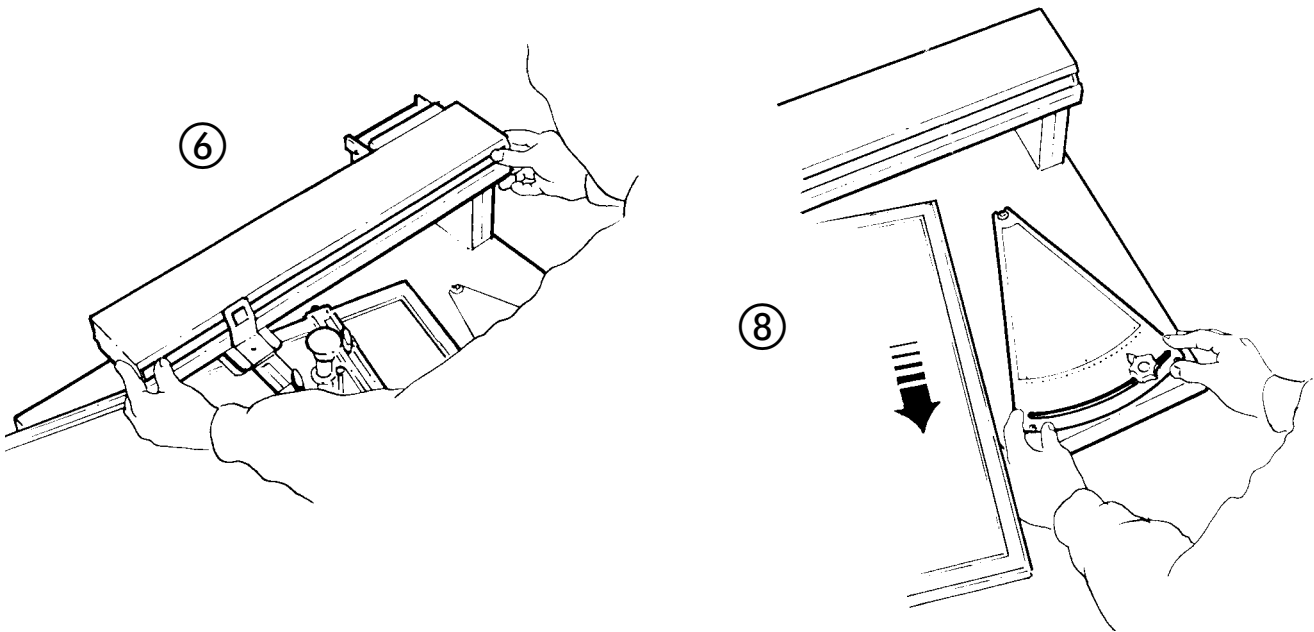

Small variations in cut dimensions can occur dependant upon the size and proportion of the oval, in most cases the error is insignificant but care needs to be used when cutting ovals below 10 cm [4"]. If in doubt check before cutting and correct as follows:-

#### Metric

For this example say an 8cm wide by 11cm long oval is required:-

1. Set the width to say 1cm less than the finished mat size *ie.* 7cm
2. Set the differential to the same dimension as for the finished mat *ie.* 11cm-8cm. = 3cm.
3. Cut the oval in the normal way.
4. Measure the width of the oval, let us say it is 7.2cm for example.
5. Compare the 7.2cm with the dimension read on the width scale.
6. Slide the width scale (*Not the cutting head*) until it reads 7.2cm.
7. Measure the length of the oval, let us say it is 11.3cm, and calculate the difference between it and the width measured previously *ie.* 11.3cm-7.2cm = 3.1cm.
8. To correct the differential scale loosen the two screws and the knob, swing the scale until it reads 3.1cm, re-tighten the screws and the knob.
9. Reset the machine to width = 8cm. & difference = 3cm. Then cut the finished oval.

#### Imperial

For this example say a 3" wide by 4" long oval is required:-

1. Set the width to say  $\frac{1}{2}$ " less than the finished mat size *ie.*  $2\frac{1}{2}$ "
2. Set the differential to the same dimension as for the finished mat *ie.* 4" - 3". = 1".
3. Cut the oval in the normal way.
4. Measure the width of the oval, let us say it is  $3\frac{1}{16}$ " for example.
5. Compare the  $3\frac{1}{16}$ " with the dimension read on the width scale.
6. Slide the width scale (*Not the cutting head*) until it reads  $3\frac{1}{16}$ "
7. Measure the length of the oval, let us say it is 4", and calculate the difference between it and the width measured previously *ie.* 4" -  $3\frac{1}{16}$ " =  $1\frac{1}{16}$ "
8. To correct the differential scale loosen the two screws and the knob, swing the scale until it reads  $1\frac{1}{16}$ ", re-tighten the screws and the knob.
9. Reset the machine to width = 3". & difference = 1" then cut the finished oval.

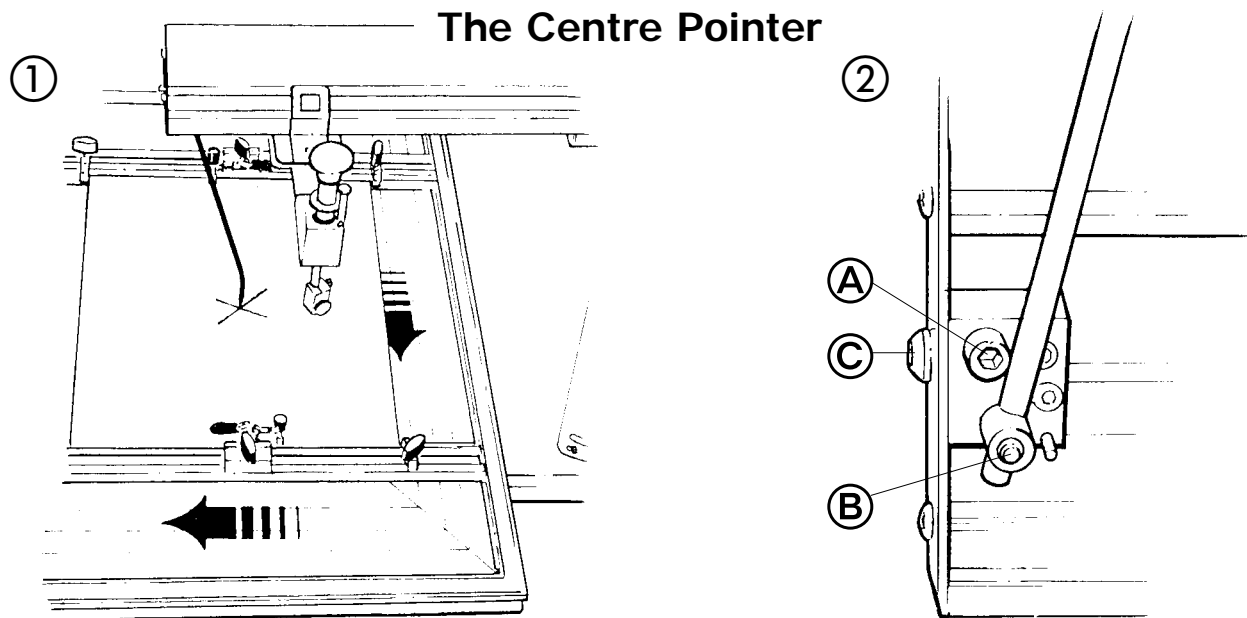

### 1. Using the centre pointer

The centre pointer indicates the centre of rotation of the turntable to enable the matboard to be placed without using the scales on the turntable. It is used for precise positioning when cutting multiple openings. The centre pointer should be pivoted into its park position under the beam when not in use.

**NOTE:** When using or setting the centre pointer always set the differential scale to the circle setting or position the turntable at 90° to the beam (portrait position).

- 1.1 Mark the centre position of the oval or circle on the matboard.
- 1.2 Swing the centre pointer from under the beam until it stops.
- 1.3 Place the matboard so that the centre mark is under the centre pointer.
- 1.4 Move the clamps to secure the board and cut the opening.

### 2. Adjusting the centre pointer for accuracy

The printed turntable grid is correctly installed when the centre lines align with the zero points on the turntable edge scales. The centre pointer should exactly indicate the crossed centre lines on the turntable grid when the differential scale is set to cut a circle or the turntable is in the 'portrait position'.

Set the differential scale to the circle position and swing the centre pointer into position. If the centre pointer appears to point to the centre of grid rotate the turntable and check that it does so for a complete revolution. If it does not proceed as follows:-

- 2.1 Lift the beam.
- 2.2 Observe the socket screw with an eccentric head **A** which limits the travel of the centre finder. Fix the 5mm hexagon wrench to it and lower the beam.
- 2.3 Adjust the pointer laterally by turning the eccentric screw until the pointer is at the centre of the grid.
- 2.4 If adjustment front to back is necessary first lift the beam and observe the small screw **B** in the end of the pivot which locks the pointer in place. Fit 3mm hexagon wrench and loosen it.
- 2.5 Lower the beam and adjust the pointer until it is at the centre of grid, lock the screw.
- 2.6 The height of the pointer can be adjusted using screw **C**.

### Cutting small Ovals and Circles

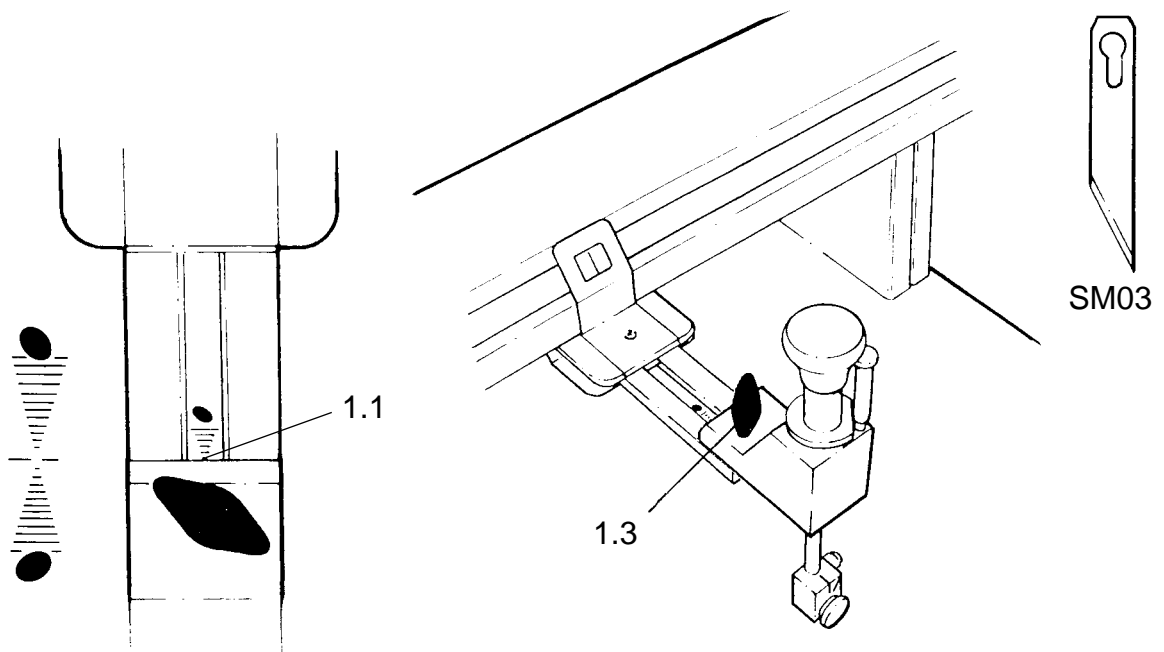

**NOTE:** When cutting very small ovals/circles better results can be achieved using the more acute SM03 blade.

#### 1. Small ovals

Distortions will occur when making very small diameter circles or ovals owing to the self alignment action of the tools.

1.1 Note the position of the cutting head against the lazy oval scale.

1.2 Set the machine to make the desired size and cut the oval/circle.

*If the top of the oval **leans to the right** move the cutting head **towards** the beam.*

*If the top of the oval **leans to the left** move the cutting head **away** from the beam.*

1.3 Loosen the thumbscrew allowing the cutting head to move towards or away from the beam.

1.4 Cut another oval in a different part of the board, check the setting and repeat the adjustment as necessary locking the thumbscrew each time.

The machine is now set to produce upright ovals in the size range for which it was adjusted. Over 10cm [4"] the ovals will remain upright throughout the range.

#### 2. Small circles

When cutting small circles the effect of the self alignment action is slightly different, the blade can become uncontrollable and very inaccurate. Moving the cutting head towards the beam as explained above will correct it.

# 5.1 The Craftsman Toolset (optional) 5.1

## Embossing

The 'Craftsman Toolset' includes two types of embossing tool:-  
A half round edged wheel that produces a narrow embossed line  
A flat edged wheel that produces a wide embossed line

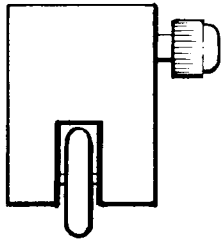

A half round edged wheel

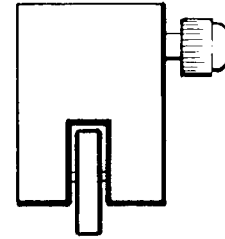

A flat edged wheel

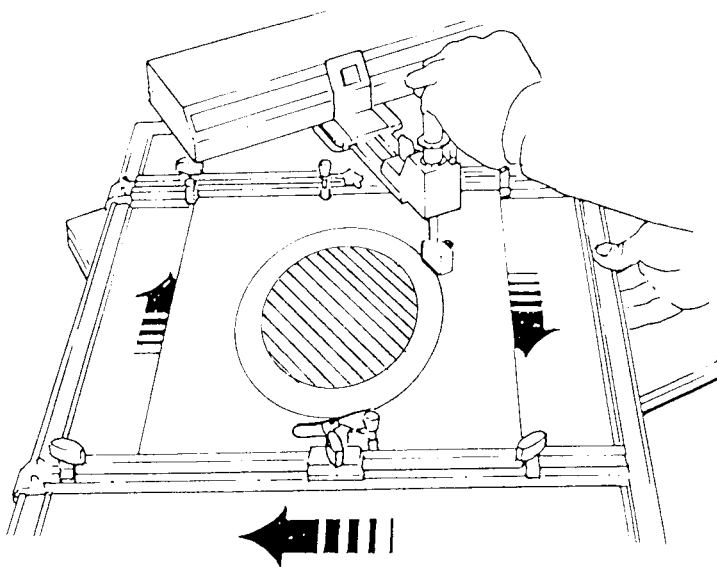
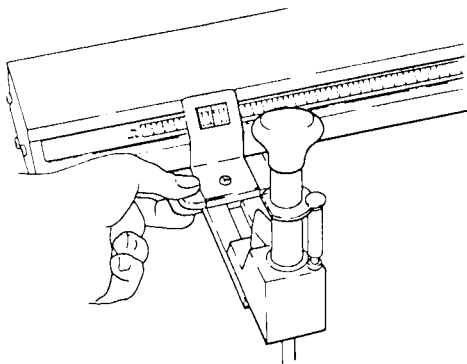

1. Cut an oval/circle of the desired size.
2. Do not alter the differential setting but increase the oval/circle width setting.
3. Fit the embossing tool and lower it onto the matboard surface.
4. Do not touch the cutting head knob, rotate the turntable by at least  $\frac{1}{4}$  turn to align the embossing tool.
5. Whilst turning apply firm pressure to the cutting head knob and continue for one or two turns until the indent line is of the desired depth.
6. Remove the mat or leave it in place if you wish to fill it with a pen line.

### Penlining

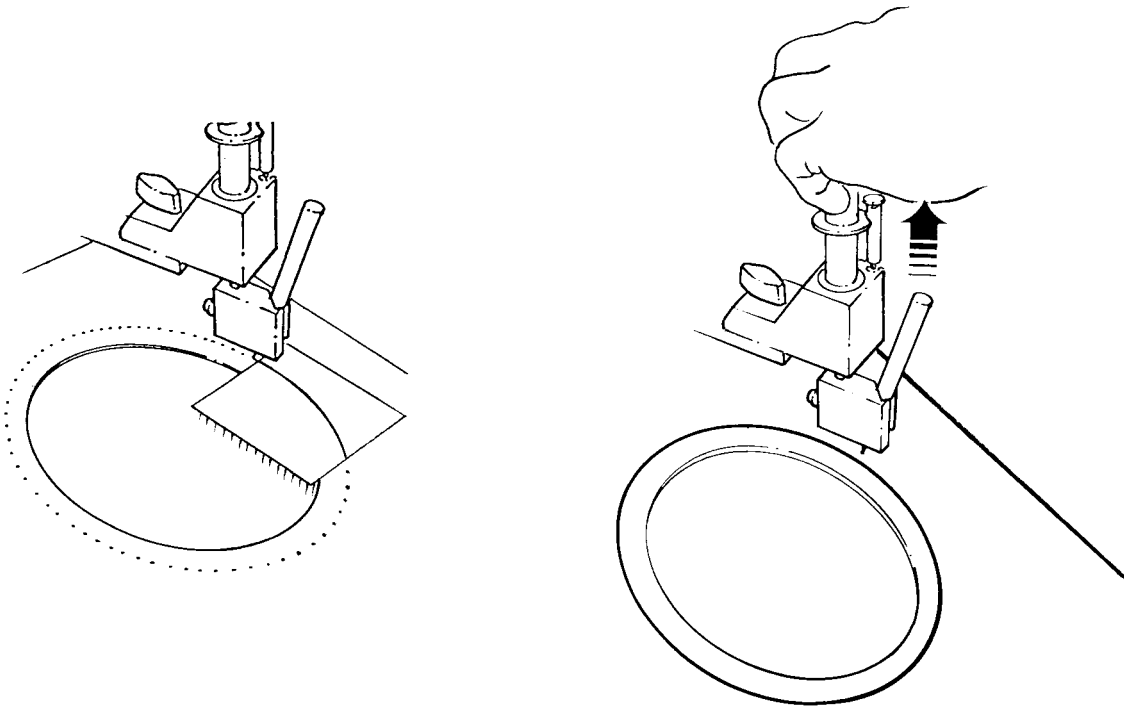

---

#### 2. Penlining

Embossing an indent before drawing the penline provides a smooth surface for the ink, prevents bleeding and ensures a reliable alignment for the pen. For most lines the thin half round embossed indent is appropriate, for a very thick pen use the broad flat embossing tool.

- 2.1 Ensure that the pen is drawing freely with no excess ink and that it is accurately clamped in the pen holder. The tip should protrude 5-10mm [ $\frac{1}{4}$ " to  $\frac{1}{2}$ "] below the bottom of the holder.
- 2.2 Do not change the width or differential settings after producing the embossed indent.
- 2.3 Place a small sheet of thin paper on the mat so that one clean edge is across the embossed line. Lower the pen until the tip is on the paper about 8cm [3"] from the paper edge.
- 2.4 Do not touch the cutting head knob at all - gravity is quite sufficient. Rotate the turntable whilst holding the paper to align the pen tip.
- 2.5 The pen will run off of the edge of the paper and into the embossed indent. Rotate the turntable slowly and consistently for at least two turns removing the paper but do not stop turning.
- 2.6 Lift the pen whilst the turntable is still moving and twist the cutting head knob to park it.

## 5.3 The Craftsman Toolset (optional) 5.3

### Cutting V-grooves

**NOTE:** The blade tips of the V-groove tool are set one behind the other but when viewed from the cutting direction the tips should appear to meet exactly without overlap. The V-groove width and depth may be changed by adjusting the nylon screw in the centre of the blade holder. Two SM02 blades are used in the V-grooving tool.

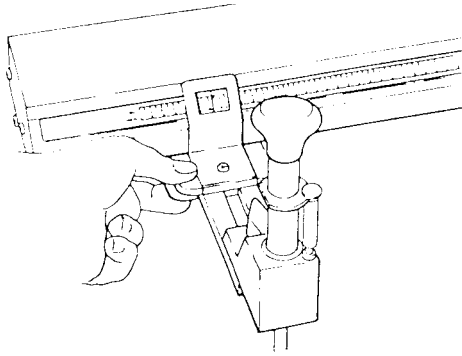

1. Cut an oval/circle of the desired size.
2. Do not alter the differential setting but increase the oval/circle width setting.

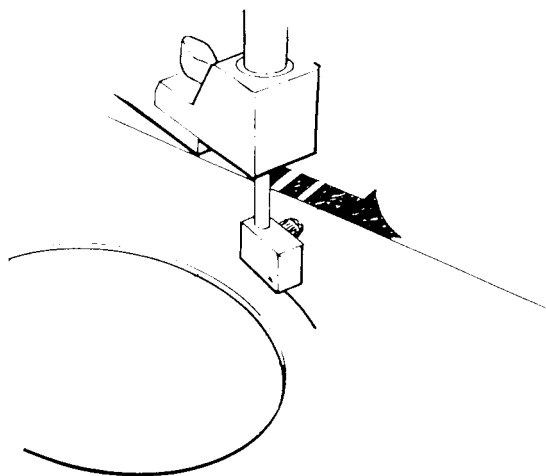

3. Fit the glass scoring tool and lower it onto the matboard surface. Rotate the table (without touching the cutting head knob) to align the tool then press on the cutting head knob to make a light indent 2cm [1"] or so long.

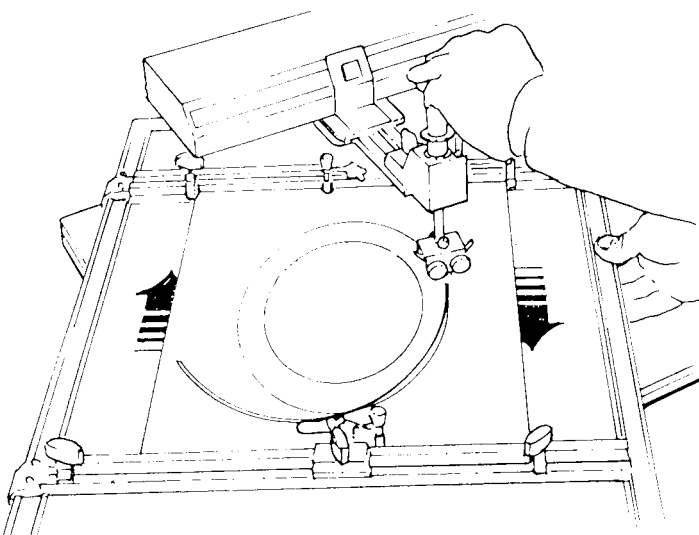

4. Remove the glass scoring tool and fit the V-groover.
5. Lower the V-groover and carefully place the tips of the two blades in the indent.
6. Place a hand on the cutting head knob and rotate the turntable one full revolution applying firm constant pressure on the cutting head knob.
7. Stop when the blades stop cutting the thin strip from the matboard. Inspect the V-groove and remove the finished mat from the clamps.

The initial hand pressure on the cutting head controls the speed of the blade entry in to the mat surface and the continued pressure can affect the depth.

# 5.4 The Craftsman Toolset (optional) 5.4

## Cutting glass Ovals/Circles

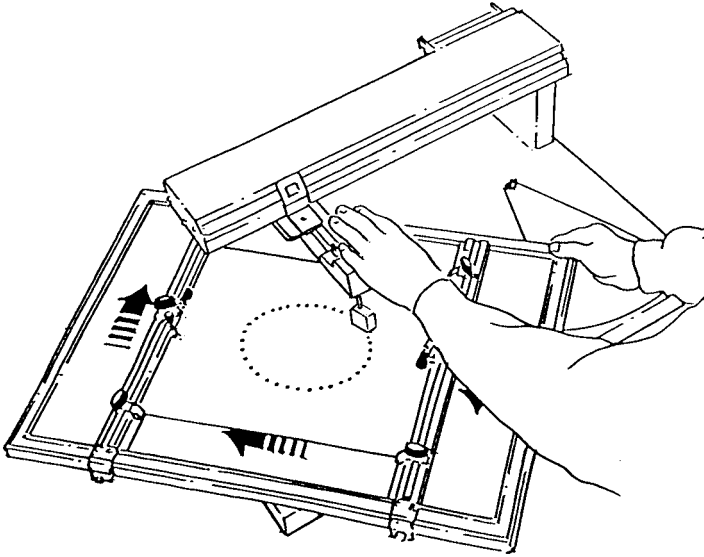

1. Clamp a piece of matboard on the turntable that is larger than the glass blank do not lay the glass on it yet.
2. Set the width and differential scales to the desired size of oval and fit the glass scoring tool to the cutting head.
3. Lower the cutting head and with light pressure score the oval shape on the matboard.

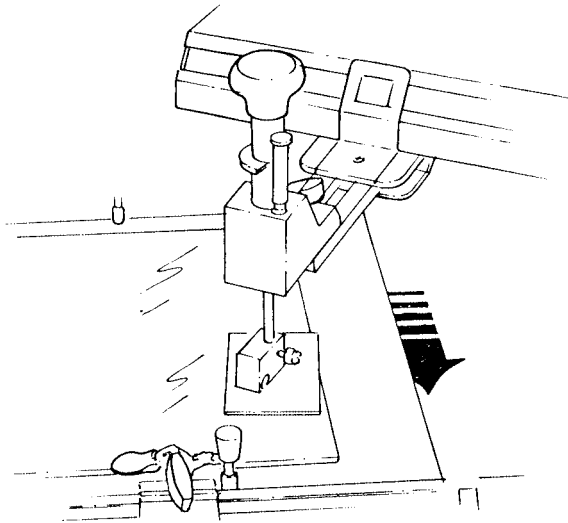

4. Measure the scored shape to confirm the accuracy.
5. Place the glass blank on the matboard and lower the cutting head onto a small piece of paper or thin card.

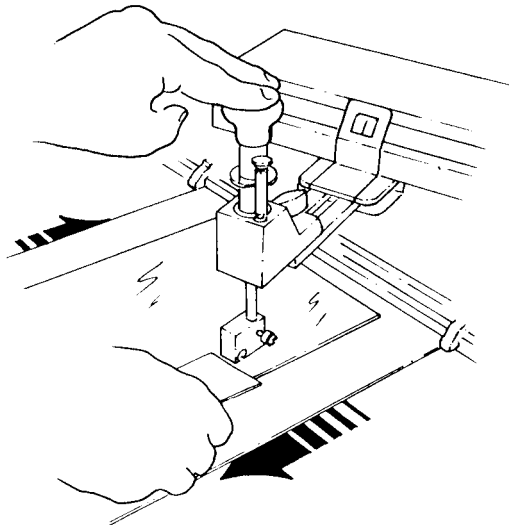

6. Rotate the turntable and apply finger pressure only to the cutting head knob, run the glass cutting wheel off the paper, then whilst still applying finger pressure remove the paper.

**WARNING:** Wear eye and hand protection when handling glass.

# 5.5 The Craftsman Toolset (optional) 5.5

## Cutting glass Ovals/Circles

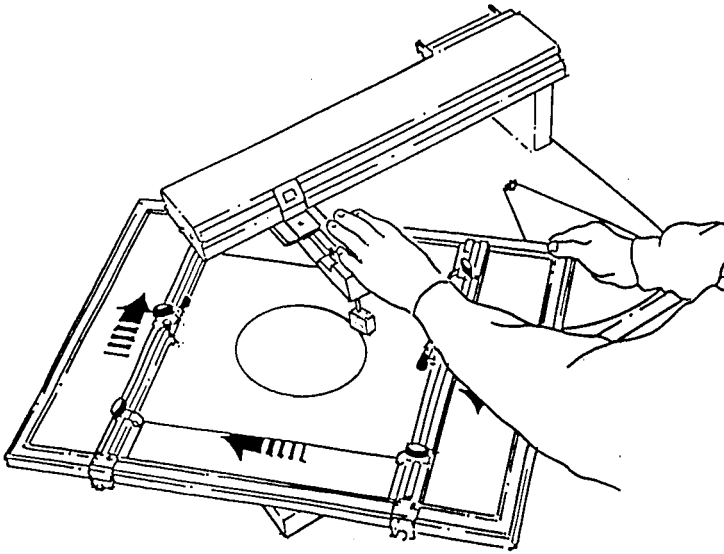

7. Rotate the turntable one complete revolution only. Stop when the score line joins up.

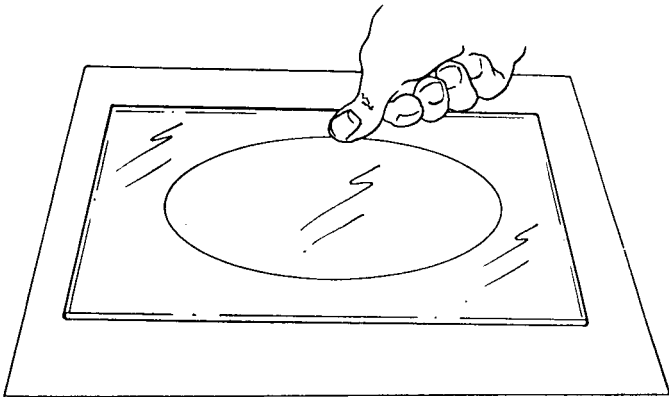

8. Turn the glass over on the matboard or a felt surface.
9. Press around the score line with the thumb or tap it to make the cut.

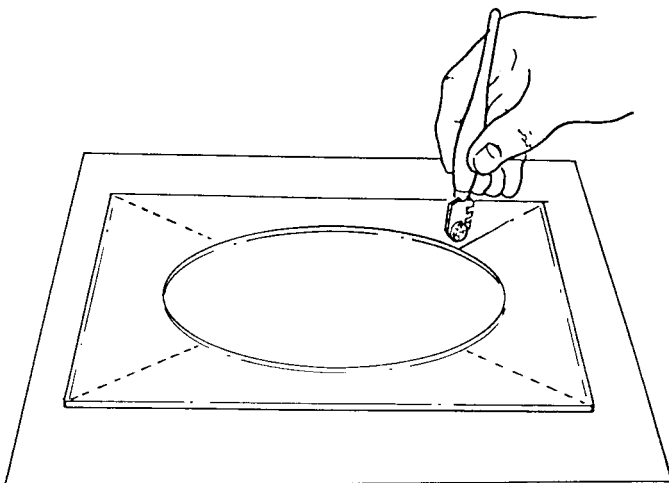

10. Starting 1mm [ $1/16$ "] from the score line score four radial lines to the outside edge.
11. Turn the glass over.
12. Starting at the edge press with the thumb or tap to break each score to remove the cut piece.

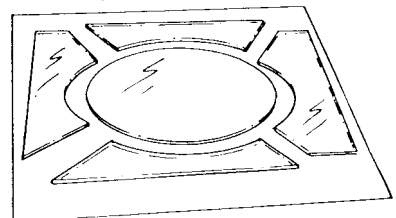

**WARNING: Wear eye and hand protection when handling glass.**

## Maintenance and Blades

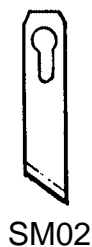

SM02



SM03



Glass cutting wheel

### Blades

The Oval 6 has been designed to use standard craft knife blades:-

Material	Operation	use blade...	
Regular matboard	Cutting all except very small ovals/circles	SM02	The
Regular matboard	Cutting very small ovals/circles	SM03	Dexter No. 3
Thick matboard and foamcore	Cutting all sizes of oval/circle	SM03	blade is also
All materials	Cutting V-grooves	SM02	suitable.

Replacement blades and glass cutting wheels are available through your Keencut distributor or from Keencut direct.

### Cleaning and Lubrication

- Clean the Oval 6 frequently with a damp or dry cloth and keep it covered when not in use. Dirt can spoil your work
- Do not use solvents, they can harm the paint finish, remove silicone lubrication and effect plastic components.
- Lubrication. Use lubricant spray, apply it with a pad or cloth. Wipe off any excess liquid with a clean cloth.
- Do not use oil, grease or all-purpose penetrating oils and sprays. Silicone spray may be used on the operating disc under the table if ever required.

### Fault Finding

#### Fault

#### Causes and Suggestions

Start/Finish mark	<ul style="list-style-type: none"> <li>- Hand Pressure applied to the cutting head before the turntable had rotated to align the cutter</li> <li>- Pressure applied to the cutting head too suddenly</li> <li>- Blade depth not correct</li> </ul>
Cutting needing more than two revolutions on regular matboard	<ul style="list-style-type: none"> <li>- Change Blade</li> <li>- Apply more pressure</li> </ul>
Poor finish on the bevel	<ul style="list-style-type: none"> <li>- Blunt or broken blade</li> <li>- Insufficient hand pressure on the cutting head</li> </ul>
Excessive blade wear or tip breakages	<ul style="list-style-type: none"> <li>- Glass cutting surface scored</li> <li>- Blade depth incorrect</li> </ul>
A double cut around part of the bevel	<ul style="list-style-type: none"> <li>- Blade depth incorrect</li> <li>- Inconsistent pressure on the blade</li> <li>- Not enough pressure on the cutting head during cutting</li> </ul>
Extreme lazy ovals (not vertical)	<ul style="list-style-type: none"> <li>- Turntable rotating in the wrong direction</li> <li>- Slide block wrongly set and adjusted (see 'Cutting small ovals')</li> </ul>
Ovals or circles not centred in matboard	<ul style="list-style-type: none"> <li>- Scales not accurately set or adjusted on the clamp bars or turntable edge.</li> </ul>
V-groove not meeting up after one revolution	<ul style="list-style-type: none"> <li>- Blade tips need resetting to meet exactly when viewed from the direction of cut. Please note that the blades are set one behind the other when viewed from below.</li> </ul>