

KEENCUT ULTIMAT GOLD

® INSTRUCTION MANUAL

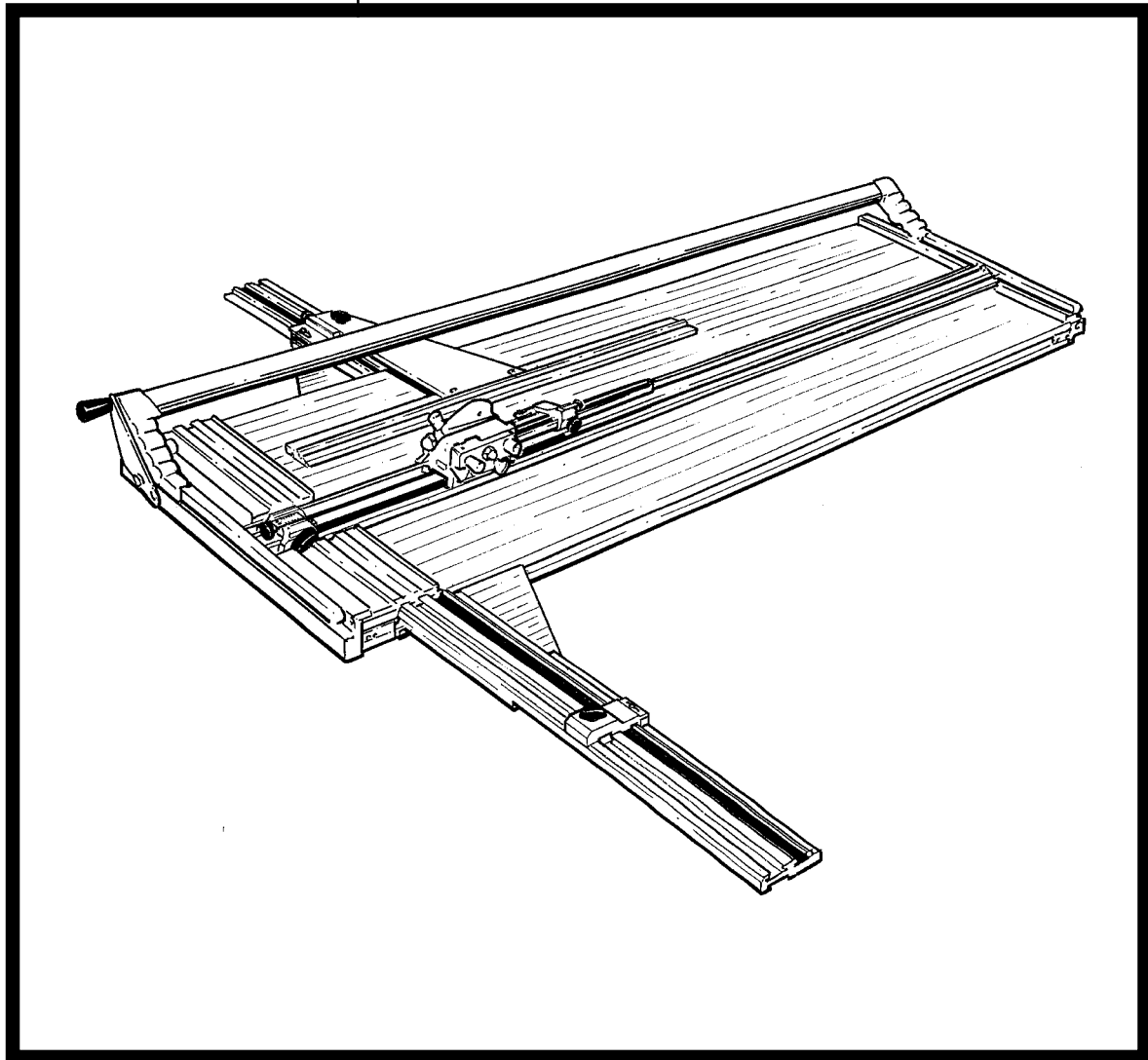

KEENCUT THE WORLD'S FINEST CUTTING MACHINES

2 Identification

- 2.1 Know your ULTIMAT GOLD

3 Preparation

- 3.1 How to Assemble your ULTIMAT GOLD
- 3.2 Know your Blades
- 3.3 Additional Matguide fittings

4 Operation

- 4.1 Cutting Board to Size
- 4.2 Setting the Measuring Arm Limit Stop
- 4.3 Setting the Blade Depth
- 4.4-4₁ Bevel Cutting
- 4.5-6 Adjusting the Limit Stops

5 Maintenance

- 5.1 Squaring
- 5.2 The Alignment of the Matguide
- 5.3 Removing the Start of Cut Rule
- 5.4 Adjusting Cutter Head Slide Bearings

6 Cutting techniques

- 6.1 Cutting Unequal Margins
- 6.2 Cutting a V-Groove
- 6.3 Cutting Offset Corner Mats
- 6.4 Cutting Multiple Openings and Title Boxes

7 Optional accessories

- 7.1 Multi-angle Cutting Gauge
Matguide Extension Kit

8 Fault finding

- 8.1 Fault finding/Maintenance

Know your ULTIMAT GOLD

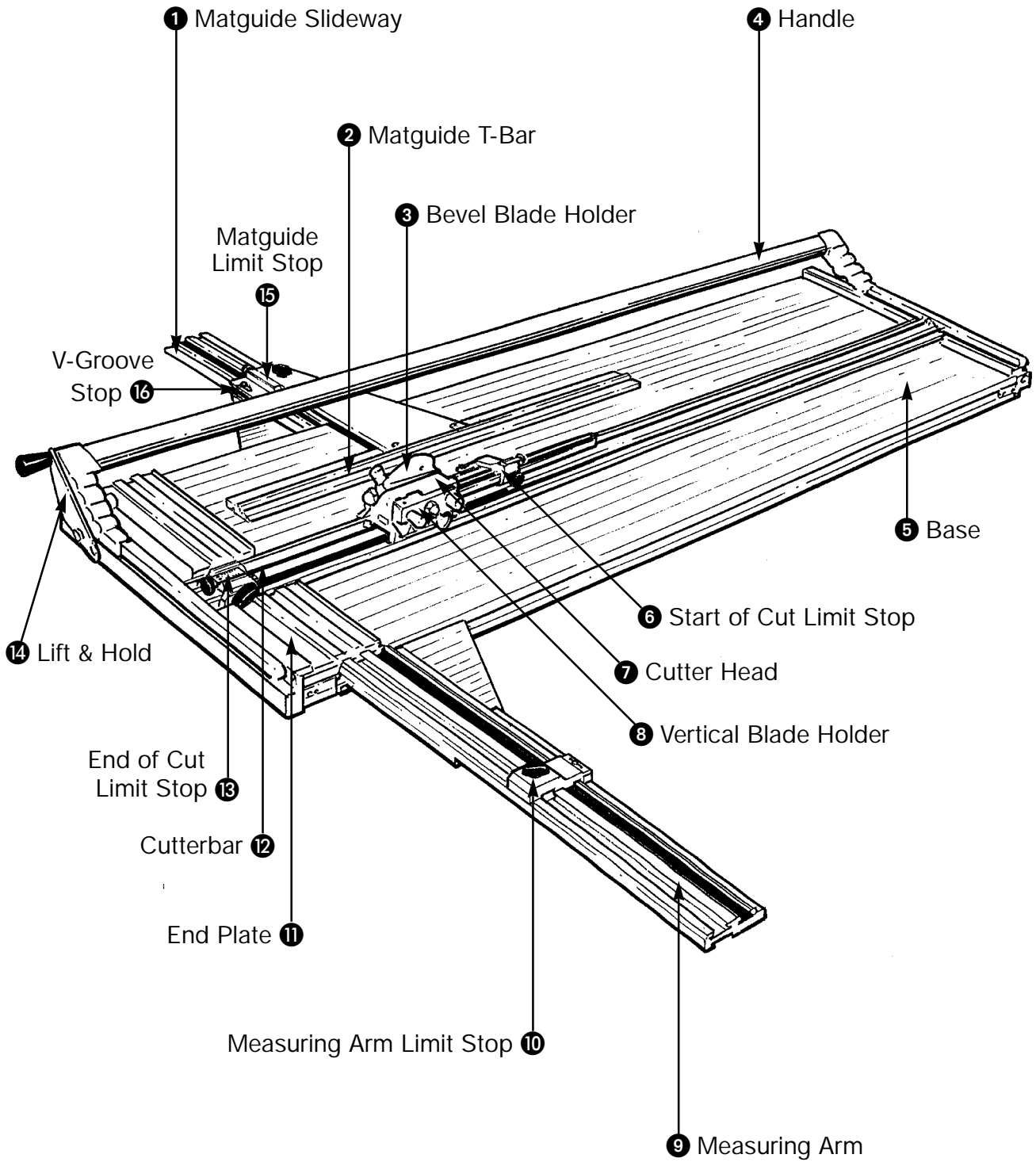

How to Assemble your ULTIMAT GOLD

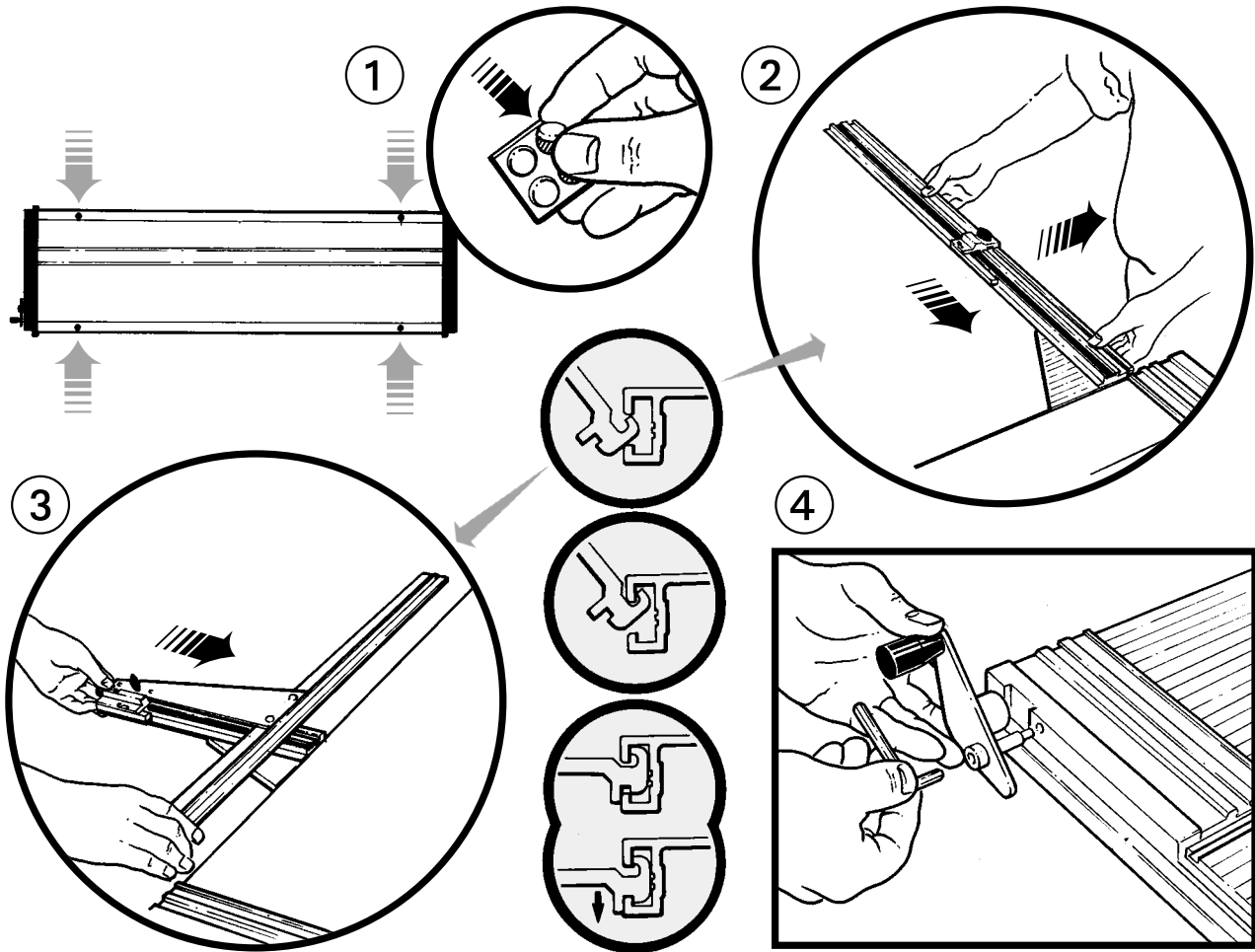

English

HOW TO ASSEMBLE YOUR ULTIMAT GOLD

- ① **THE RUBBER FEET** are supplied with self adhesive on the back. Position them as shown on the underside of the Base, not on the End Plate.
- ② **THE MEASURING ARM** is used when cutting matboard to size (sizing) and can be removed when bevel cutting. Hold the Measuring Arm at 45 degrees to the Base and forward of the End Plate. Present the Measuring Arm into the slot in the edge of the Base. Engage the Measuring Arm upwards into the Base slot and lower the Measuring Arm to horizontal. Lift the right hand end of the Measuring Arm and slide it towards you. Reverse the instructions to remove the Measuring Arm.
- ③ **THE MATGUIDE T-Bar** is used when bevel cutting and can be removed when sizing matboard. Clip Matguide Slideway into the Base slot. Check the Matguide Slideway is level with the base. The plastic screw and lock nut on the underside of the slideway can be adjusted if necessary. Slacken the wingbolt on the T-bar and slide it onto the Matguide Slideway, fasten the wingbolt. To remove the Matguide when sizing matboard either slide the T-bar from the Matguide Slideway or unclip the Matguide complete.
- ④ **THE LIFT AND HOLD** is used to raise and hold the Cutterbar above the base so you can have both hands free when positioning the matboard ready for cutting or when adjusting the Matguide T-Bar. Position the Lift and Hold and fit the screw into the threaded hole and tighten using the 4mm hexagon wrench.

KEY: ① Matguide Slideway ② Matguide T-Bar ⑤ Base ⑨ Measuring Arm ⑪ End Plate ⑭ Lift and Hold

Know your Blades

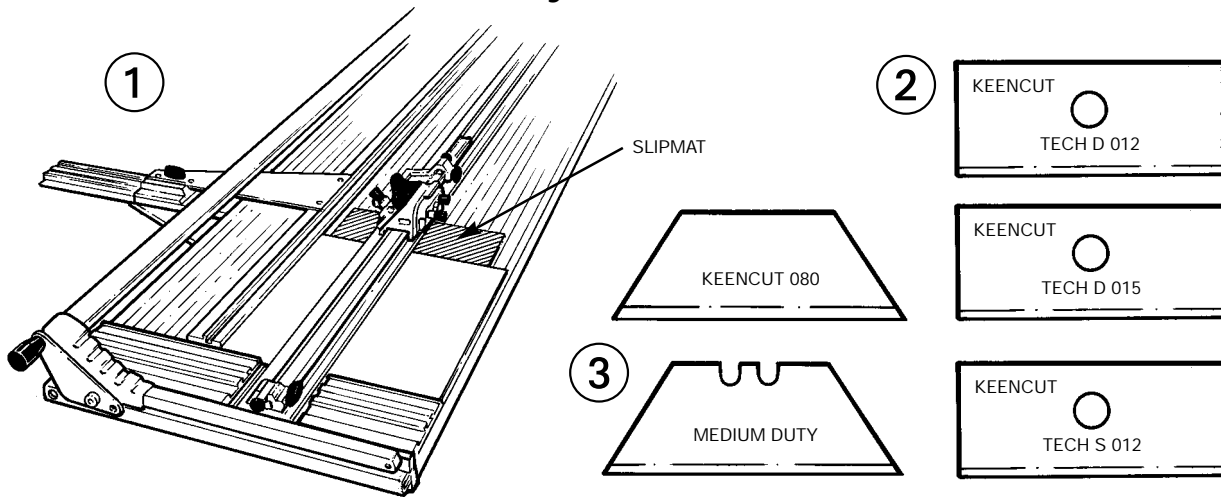

English

- ① **THE SLIPMAT** is used under the matboard when bevel cutting, this ensures crisp clean cutting. Make it from standard matboard. Avoid using dense matboard such as black core. Size - approximately 15cm (6") wide and either the full cutting length of the Ultimat long, or at least 5cm (2") longer than the longest mat you are going to cut.

When using - ensure the white side is uppermost and replace it when the surface damage becomes obvious.

- **BLADES** are one of the most critical parts of the machine, in all cases the blade used should be the one most suited to the job in hand - when bevel cutting a precision ground and honed blade is required with an oil free surface (many blades are packed with an oil film to protect them) and the surface should be corrosion free.

The hardness and toughness of the blade is also critical.

All these factors add to the manufacturing cost of quality blades, however, the option to use inexpensive blades leaves quality to chance and can increase wastage.

- ② **BEVEL CUTTING** blades used on the Ultimat are rectangular and come in three varieties:-

TECH D 012	double ground edge 0.012" thick (knife edge)	For general purpose cutting on most matboard (some are supplied with your machine)
TECH D 015	double ground edge 0.015" thick	Both can give better results on some of today's thick and dense matboards only trial and error can prove any benefit. If you require sample blades contact Keencut direct and a small quantity will be sent F.O.C. We would be pleased to know your results!
TECH S 012	single ground edge 0.012" thick (chisel edge)	

Please Note: when using the Tech S.012 blades you can only use the one tip as indicated on the blade.

- **BLADE DEPTH** is critical when bevel cutting. Too deep and hooking will occur, too shallow and the blade will not penetrate or meet at the corners. The tip of the blade should cut through the matboard and score the slipmat about 0.5 - 1 mm (1/64" - 1/32") deep. The method of adjustment is explained later.
- **HOOKING** is when a curved cut is produced at the beginning of a bevel cut. This is caused by the blade bending or moving sideways when being pushed into the matboard, the blade then springs or moves back to its correct position as it begins to travel down the cut.
- **PREVENTION** is covered in the "Fault finding" section on page (12).
- ③ **VERTICAL CUTTING** is carried out using a standard trapezium shaped blade, these are thicker (0.017") and tend to distort less than the rectangular blades for vertical cutting.

Generally (clip frames excepted), providing the edge is straight, square and clean the quality of finish of the cut is less critical than with bevel cutting therefore the less expensive "medium duty utility" blade can be used, for better results use "Keencut 080" blades.

Blade depth is important. The further the tip of the blade extends through the matboard the more difficult it is to cut.

Additional Matguide fittings (fittings optional)

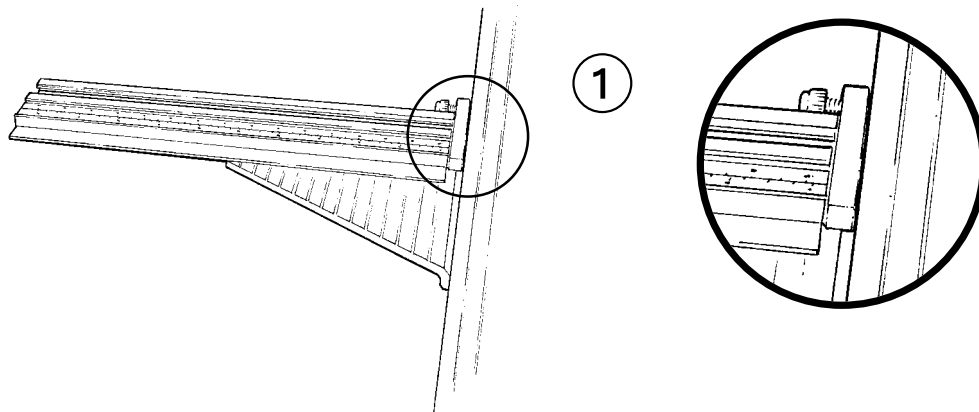

English

Matguide Lock

Used if the Machine is set on a sloping table top to prevent the Matguide sliding down the edge of the base through vibration.

- ① Fit the Lock between the edge of the base and the Matguide slideway, tighten the screw and fit the T-bar.

Unequal Margin guide stops

When cutting a large batch of unequal margin mounts (see 'Cutting unequal margins') the additional stops (a) and (b) can be fitted to the Matguide Slideway as shown. When the stops are set in the appropriate positions the T-bar can be quickly moved to either of the two required dimensions.

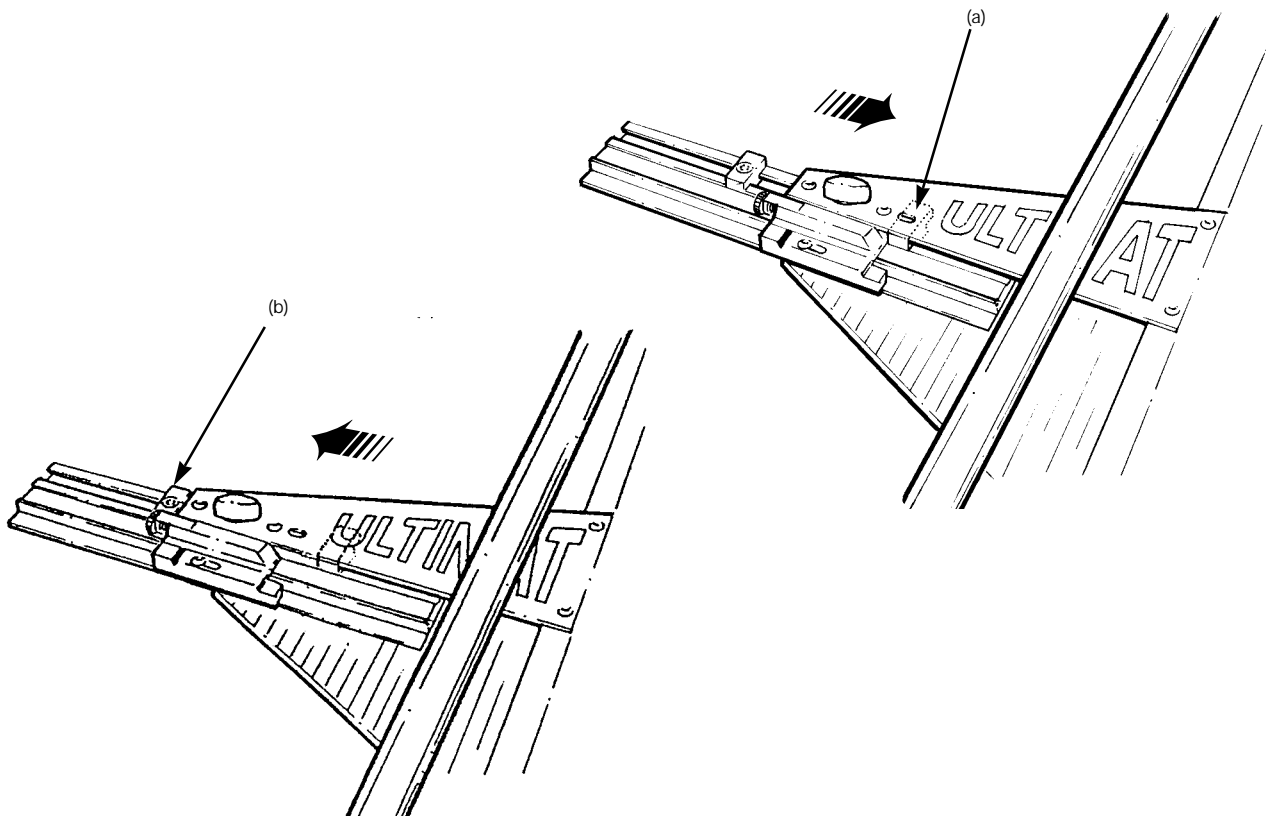

Cutting Board to Size

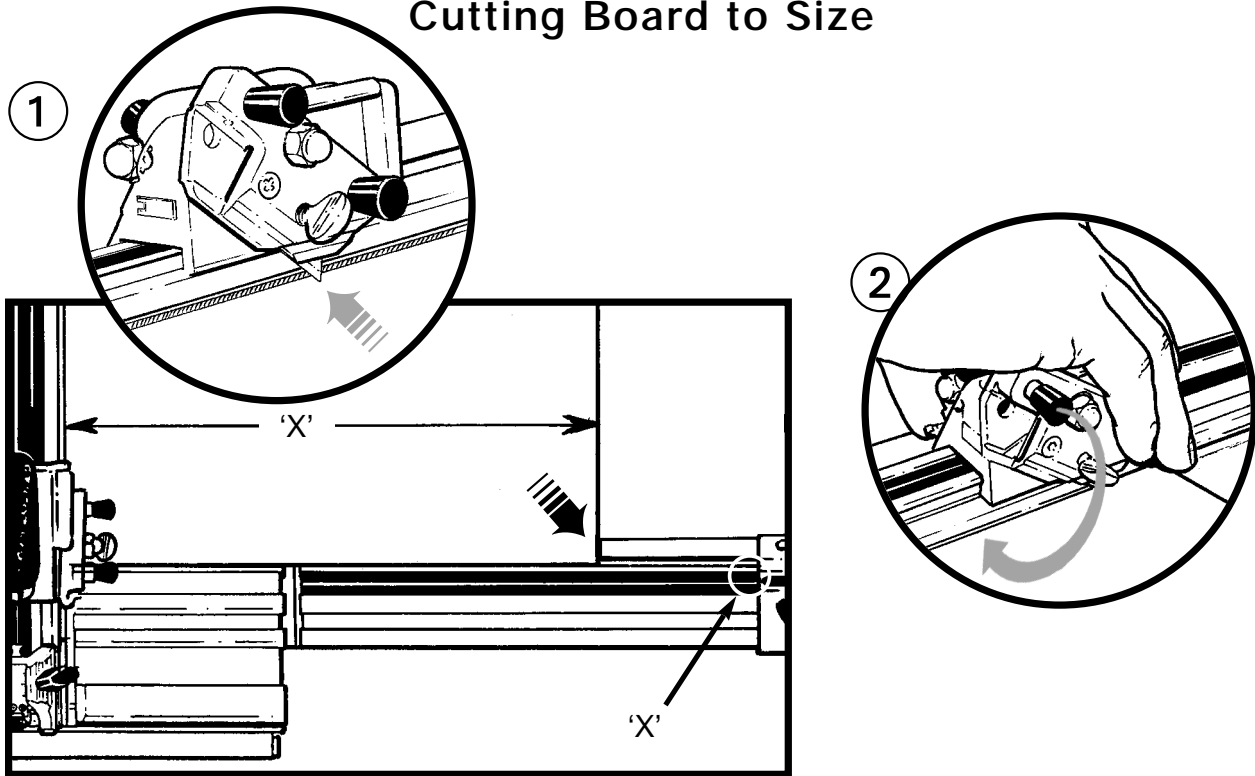

English

- **CUTTING BOARD TO SIZE** using the vertical cutter, fitted with a trapezium shaped blade adjust the depth so the tip of the blade **JUST** protrudes the board being cut. It is not necessary to use a slip mat when vertical cutting.

To enable the blade to be quickly set for the different thickness of materials such as paper, matboard and foamcore no preset stop is fitted.

Fit the Measuring Arm and ensure it is positioned correctly. Remove the Matguide if necessary.

Set the Measuring Arm Limit Stop to the dimension required.

- ① Place the matboard under the Cutterbar and position it so the bottom right corner is against the Stop. Lower the Cutterbar. Slide the Cutter Head away from you past the top edge of the matboard.
 - ② Ensure the vertical lock is off, (by turning clockwise) depress the blade holder and pull the Cutter Head towards you. **Do not press on the handle.**
- The *Vertical Blade Holder* can be locked in either the cutting position or the rest position. Twist counter-clockwise to lock, clockwise to unlock.

KEY: ⑦ Cutter Head ⑧ Vertical Blade Holder ⑩ Measuring Arm Limit Stop ⑫ Cutterbar

You will
need



Setting the Measuring Arm Limit Stop

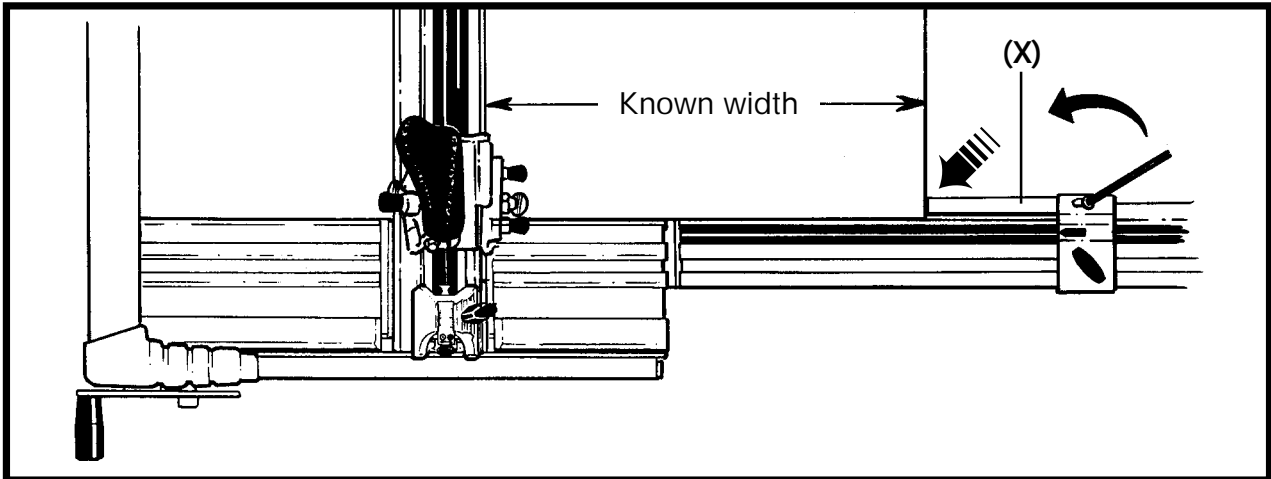

English

- **CHECK** that the matboard has been cut to the correct size. If the Measuring Arm has not given an accurate measurement then the Measuring Arm Stop finger (X) can be adjusted using a 3mm hexagon wrench.
- **BEWARE:** Some new matboard may not be square.
- **THE SQUARENESS** of the Cutterbar to the End Plate and Measuring Arm is set in the factory before despatch. However it can easily be adjusted if necessary. Refer to "Squaring Instructions" page (5.1).

Setting the Blade Depth

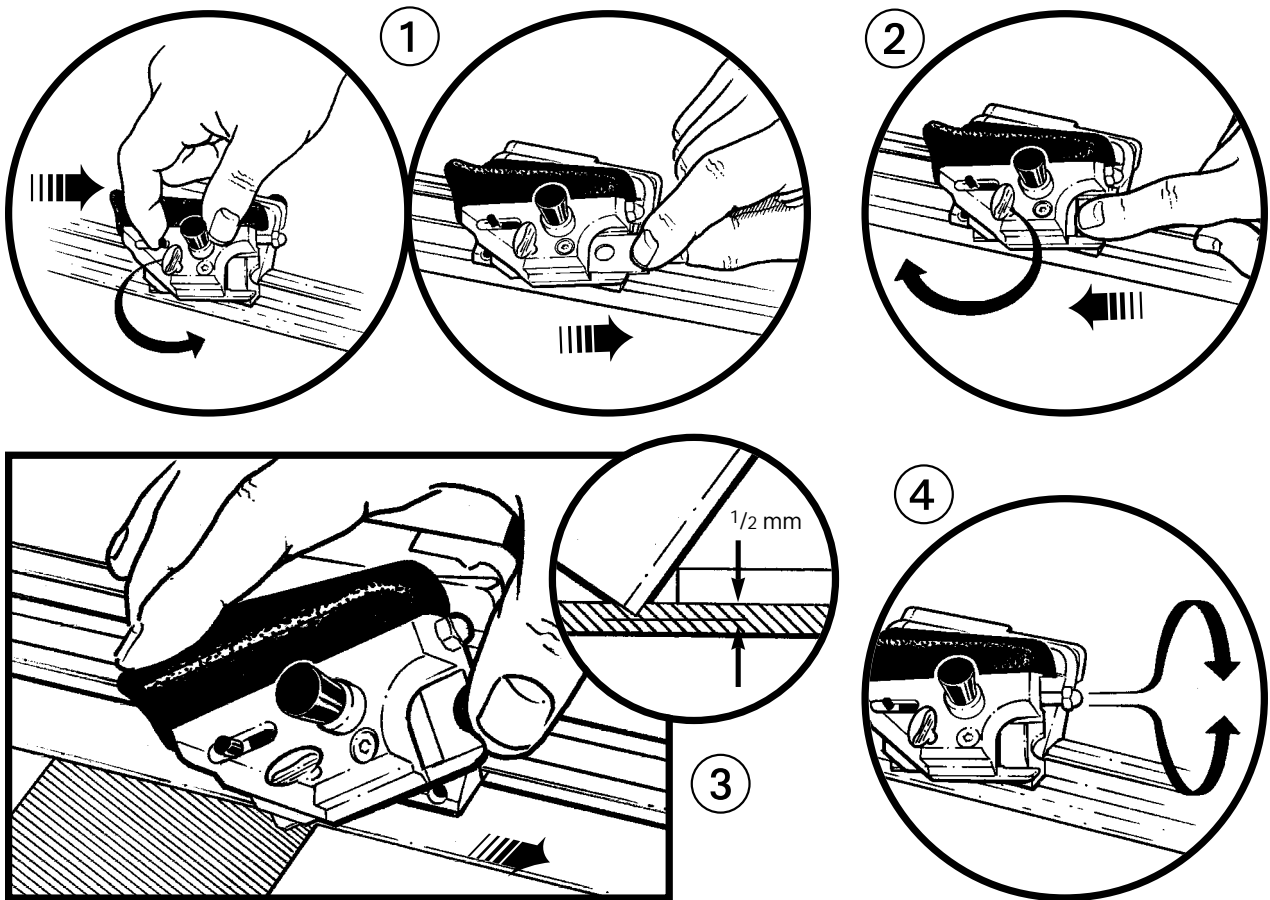

English

■ CUTTING A BEVEL EDGED APERTURE

TIP Change your blade regularly. The cost of half a blade (two cutting tips per blade) compared to matboard is negligible.

The Ultimat has been tested and adjusted to give accurate results on a standard matboard. You may need to adjust the machine to give accurate cutting if your matboard is of a slightly different thickness to that of the test mat. Initially, do not worry about border width or over/under cuts we will explain that later.

① **TO SET THE BLADE** firstly remove the blade left in the holder from test cutting.

Slacken the clamping screw.

Pull the ejector back and remove the blade from the back of the holder.

② Slide a new blade in from the back of the holder, press it forward against the blade stop.

Fasten the clamping screw.

■ BLADE DEPTH

③ Place the slip mat and matboard in the machine as for normal cutting.

Slide the Cutter Head towards the edge of the matboard.

Depress the blade holder fully to penetrate into the slip mat at a point close to the edge of the matboard.

Inspect the amount of blade penetration into the slip mat, it should be 0.5 - 1mm ($1/64''$ - $1/32''$).

If not

④ **ADJUST THE BLADE DEPTH** Slacken the clamping screw pull out and turn the blade depth adjustment screw clockwise to reduce the depth, counter-clockwise to increase it. Press the blade forward against the blade stop tighten the clamping screw and check the blade depth.

KEY: ③ Bevel Blade Holder ⑦ Cutter Head

Bevel Cutting

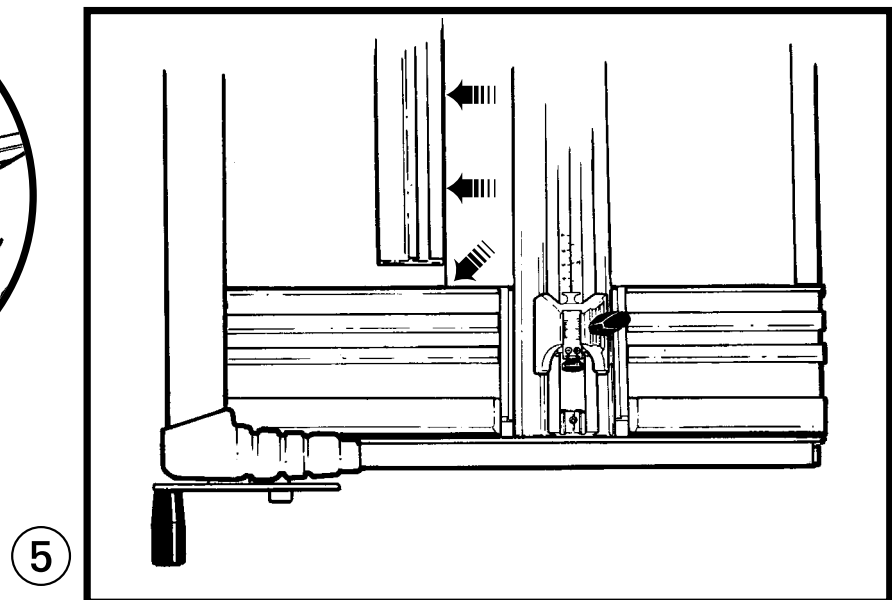
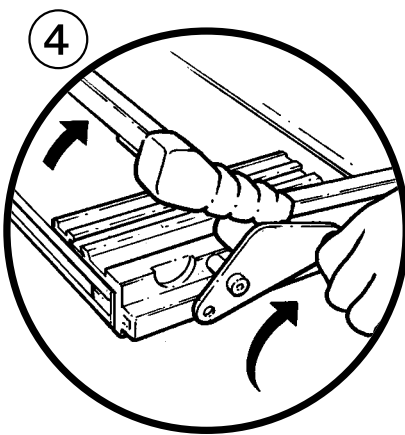
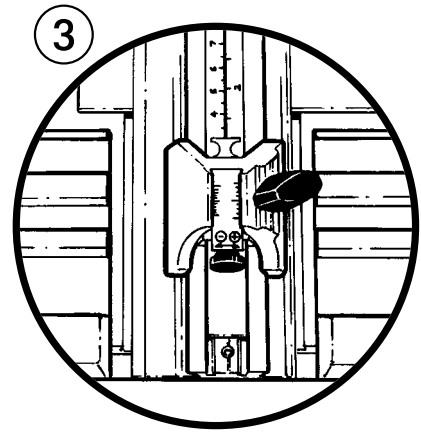
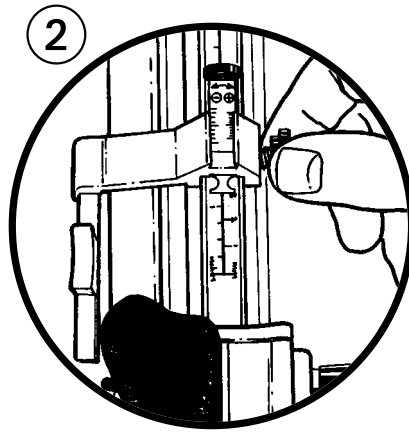
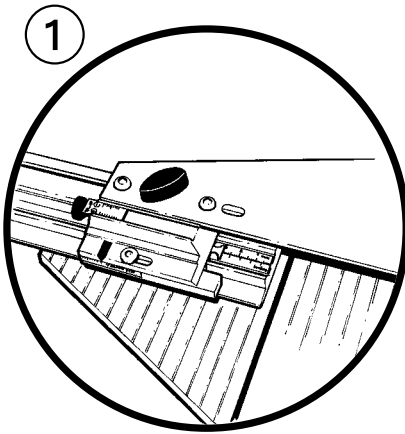

English

- **THE LIMIT STOPS** on the *Ultimat Gold* are colour coded for ease of explanation. **Do not alter the cursor settings at this stage**, adjust the limit stops by means of the large black wingknob only, we will explain cursor adjustment later.

Place your slip mat in position.

- ① Lock the Matguide Limit Stop (Blue) on 3 (cms or inches) - *this sets the border width.*
- ② Lock the Start of Cut Limit Stop (Green) on 3 (cms or inches) - *this will position the blade in the correct place when you start cutting*
- ③ Lock the End of Cut Limit Stop (Red) on 3 (cms or inches) - *this stops the blade in the correct position.*
- ④ Lift the Cutterbar using the Handle or the Lift and Hold.
- ⑤ Place the matboard coloured face down on the slip mat.

Ensure the two Mat edges are aligned against the Matguide and the End Plate.

Lower the Cutterbar to clamp the matboard and check the matboard contact with the Matguide and End Plate.

KEY: ④ Handle ⑥ Start of Cut Limit Stop ⑪ End Plate ⑫ Cutterbar ⑬ End of Cut Limit Stop
⑭ Lift and Hold ⑮ Matguide Limit Stop

Bevel Cutting

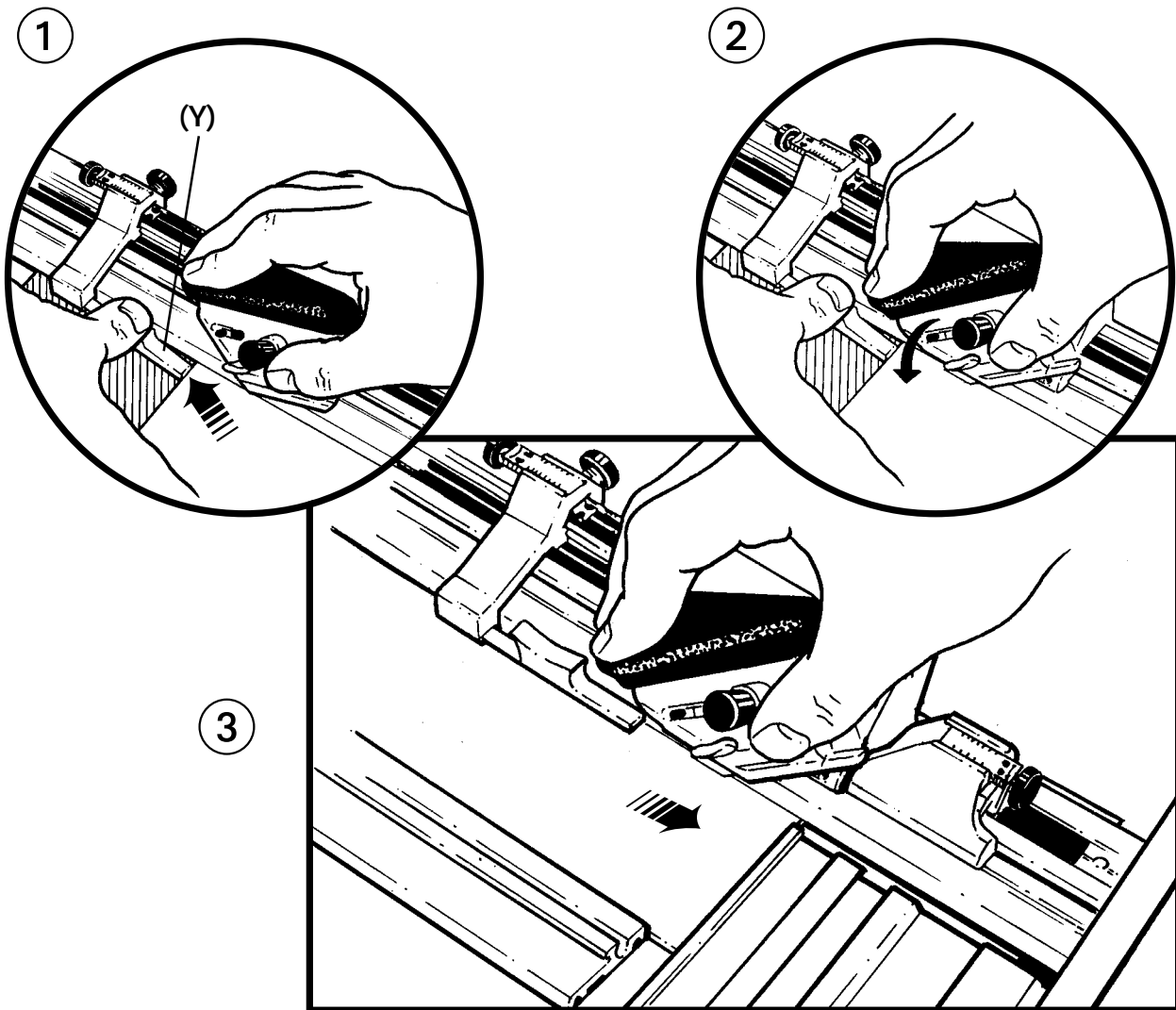

English

■ THE LIMIT STOPS (cont)

- ① Move the Cutter Head beyond the far edge of the matboard. Depress the Start of Cut Finger (Y) with the thumb of the left hand until it touches the surface of the slip Mat.
Pull the Cutter Head towards you until the Start of Cut Finger connects with the edge of the matboard and stops.
- ② Hold the Start of Cut Finger down and fully insert the blade with firm downward pressure on the Bevel Blade Holder. Release the Start of Cut Finger.
- ③ Make the cut by pulling the cutter head until it stops against the End of Cut Limit Stop.

DO NOT REST YOUR HAND ON THE HANDLE WHILST CUTTING AS IT WILL SPOIL THE RESULTS

Release the Bevel Blade Holder.

Make three more cuts in the same way after turning the matboard counter-clockwise each time.

To check if the cuts are accurate measure the border width on the white side of the matboard and look for over/under cuts in all corners on the coloured side. If there are inaccuracies refer to "Adjusting the Limit Stops" page (10 - 11).

KEY: ③ Bevel Blade Holder ⑦ Cutter Head ⑬ End of Cut Limit Stop

Adjusting the Limit Stops

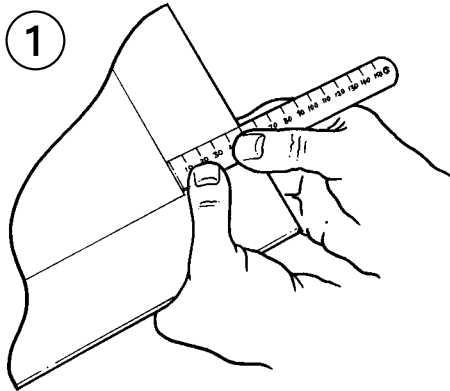

2

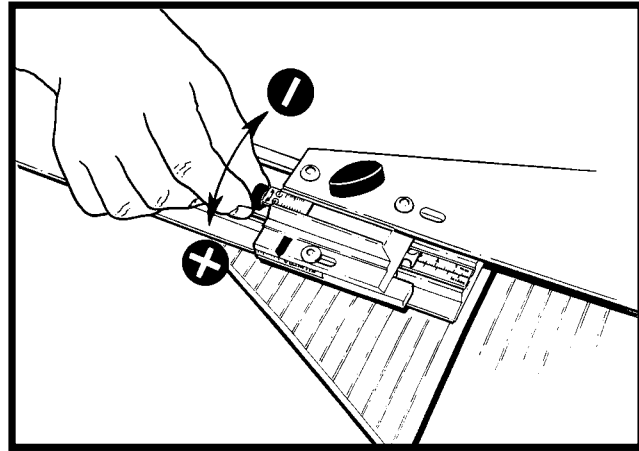

English

■ **ADJUSTING THE LIMIT STOPS** is a 2 stage process, but in most cases the first stage can be omitted.

■ **STAGE 1**

Cut a Mat as described before, (with all limit stops set at say 3) but you only need to make 2 cuts.

① Measure the border width on the back (white) face of the Mat.

If the border width is too wide, by say 1mm ($1/16''$) adjust the Matguide cursor (blue) by 1mm ($1/16''$) turning the adjustment screw in the **-** direction.

② If the border width is not wide enough, by say 1mm ($1/16''$), adjust the Matguide cursor (blue) by 1mm ($1/16''$) turning the adjustment screw in the **+** direction.

In general when adjusting the blue cursor turn the adjusting screw: -
+ to increase border width **-** to reduce border width

Reset the Matguide T-Bar to 3 in the normal way using the wingbolt (A)

■ **STAGE 2**

Make another two cuts in the Mat (taking note of which corner is made between them if you already have other cuts in the Mat).

Inspect the corner made by the two cuts for over or under cutting on the coloured side of the Mat.

KEY: 15 Matguide Limit Stop

Adjusting the Limit Stops

1

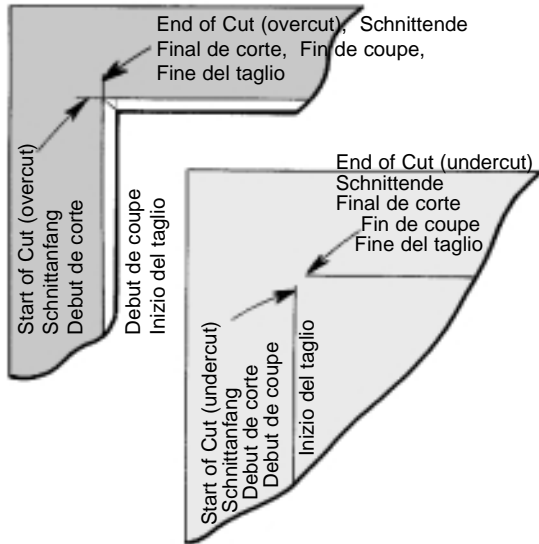

2

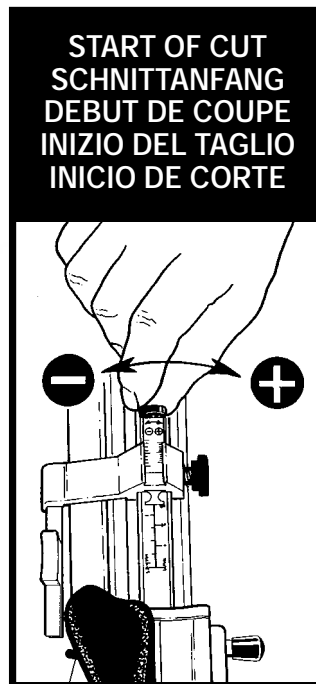

3

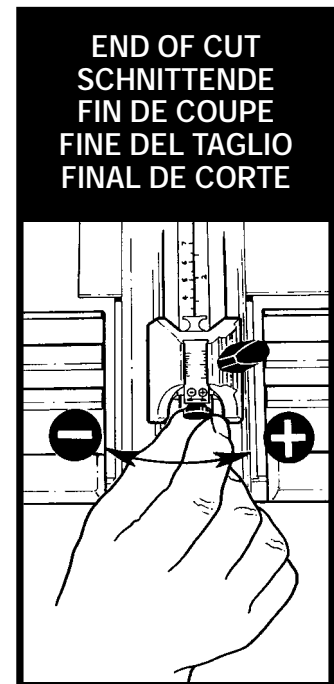

English

	START OF CUT ②		END OF CUT ③	
	OVERCUT	UNDERCUT	OVERCUT	UNDERCUT
①	Measure/Estimate the length of the undercut/overcut			
②	Move the start of cut cursor (green) the amount measured by turning the adjustment screw in the - direction to reduce the cut.	Move the start of cut cursor (green) the amount measured by turning the adjustment screw in the + direction to extend the cut.	Move the end of cut cursor (red) the amount measured by turning the adjustment screw in the - direction to reduce the cut.	Move the end of cut cursor (red) the amount measured by turning the adjustment screw in the + direction to extend the cut.
③				
	Reset the start of cut (green) and end of cut (red) limit stops to 3 (cms/inches) in the normal way.			

All the Stops have now been adjusted and set to cut an accurate mat for the thickness of matboard you have selected. The Matguide Limit Stop should not go out of adjustment when cutting different types and thickness of matboard, therefore, stage 1 of the adjusting procedure should not normally be needed. Just a check from time to time is all that is necessary. As a general rule with all the cursors:-

Turn the adjusting screw.

In the **+** direction to increase the length of the cut
 In the **-** direction to decrease the length of the cut.

You will need

Squaring

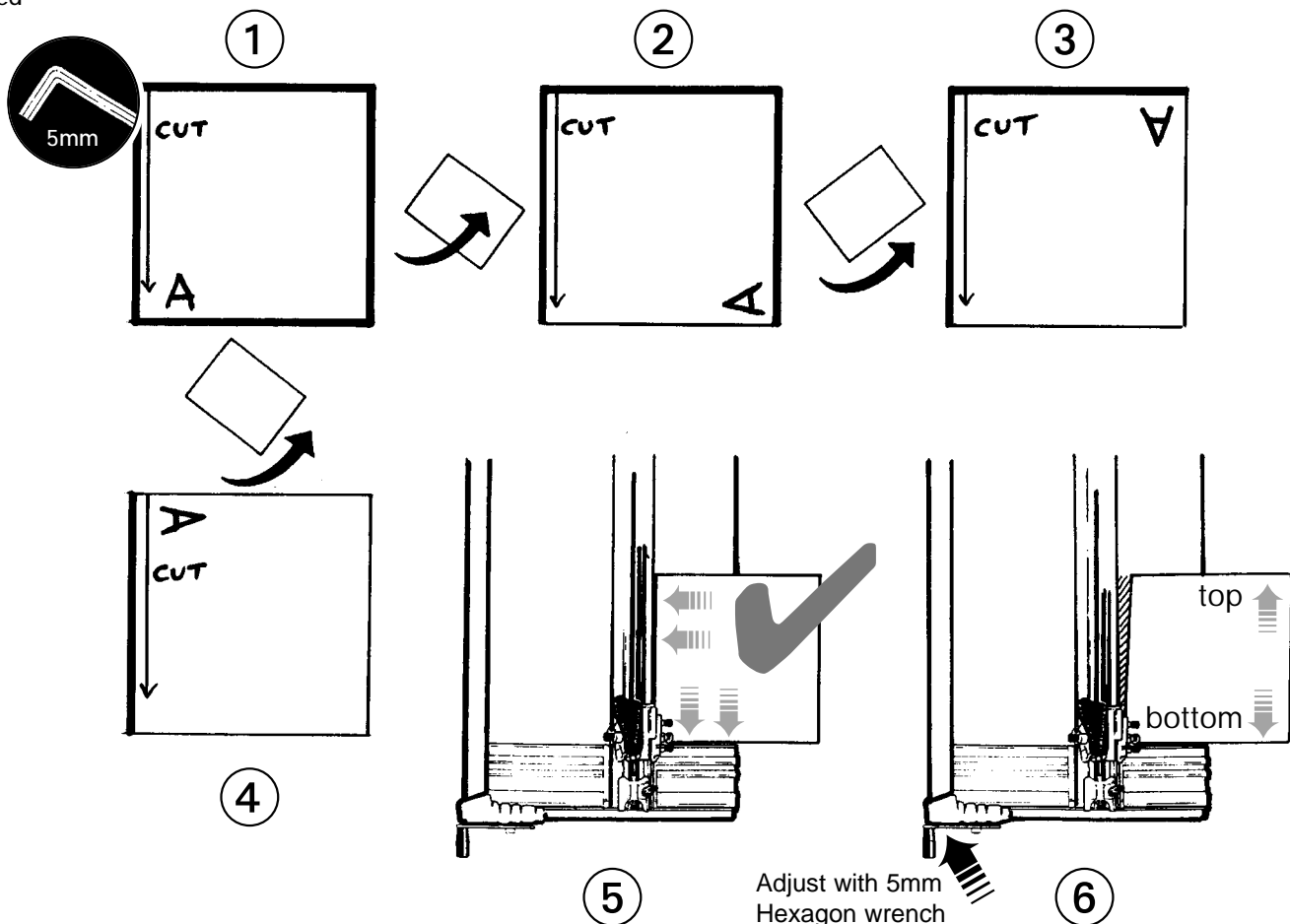

English

YOU SHOULD NOT NEED TO ADJUST THE SQUARING OF THE MACHINE!

- **SQUARING THE CUTTER BAR AND MEASURING ARM TO THE END PLATE** is carried out in our factory before despatch of all new machines. Therefore adjustment should never be necessary.

Remove the Measuring Arm.

Take a matboard at least 65 x 65cm (25 x 25") in size.

- ① Clamp it under the Cutterbar and trim off approx 1cm ($1/2"$) using the vertical blade, ensuring the bottom edge is in close contact with the End Plate.
- ② Turn the Mat a quarter of a turn counter-clockwise and trim the same amount from the second edge.
- ③ Repeat for the third edge.
- ④ And again for the fourth edge, always making sure the bottom edge of the Mat is in close contact with the End Plate.
- ⑤ Rotate the Mat a quarter of a turn counter-clockwise but this time place the bottom edge on the End Plate and slide it to the left until it comes into contact with the Cutterbar. If the Mat comes into contact with the Cutterbar along its whole length the machine is square.
- ⑥ If there is a gap between the matboard and the Cutterbar, then this gap represents four times the error of the machine.

Adjust the angle of the End Plate by turning the Squaring Adjustment Screw with the 5mm hexagon wrench. Turn it clockwise to adjust if the gap is at the bottom of the matboard and turn it counter-clockwise to adjust if the gap is at the top of the matboard.

Close the gap between the Cutterbar and the End Plate by a quarter.

Repeat the test and make further adjustments if necessary.

KEY: ⑨ Measuring Arm ① End Plate ⑫ Cutterbar

The Alignment of the Matguide T-Bar

You will need



①

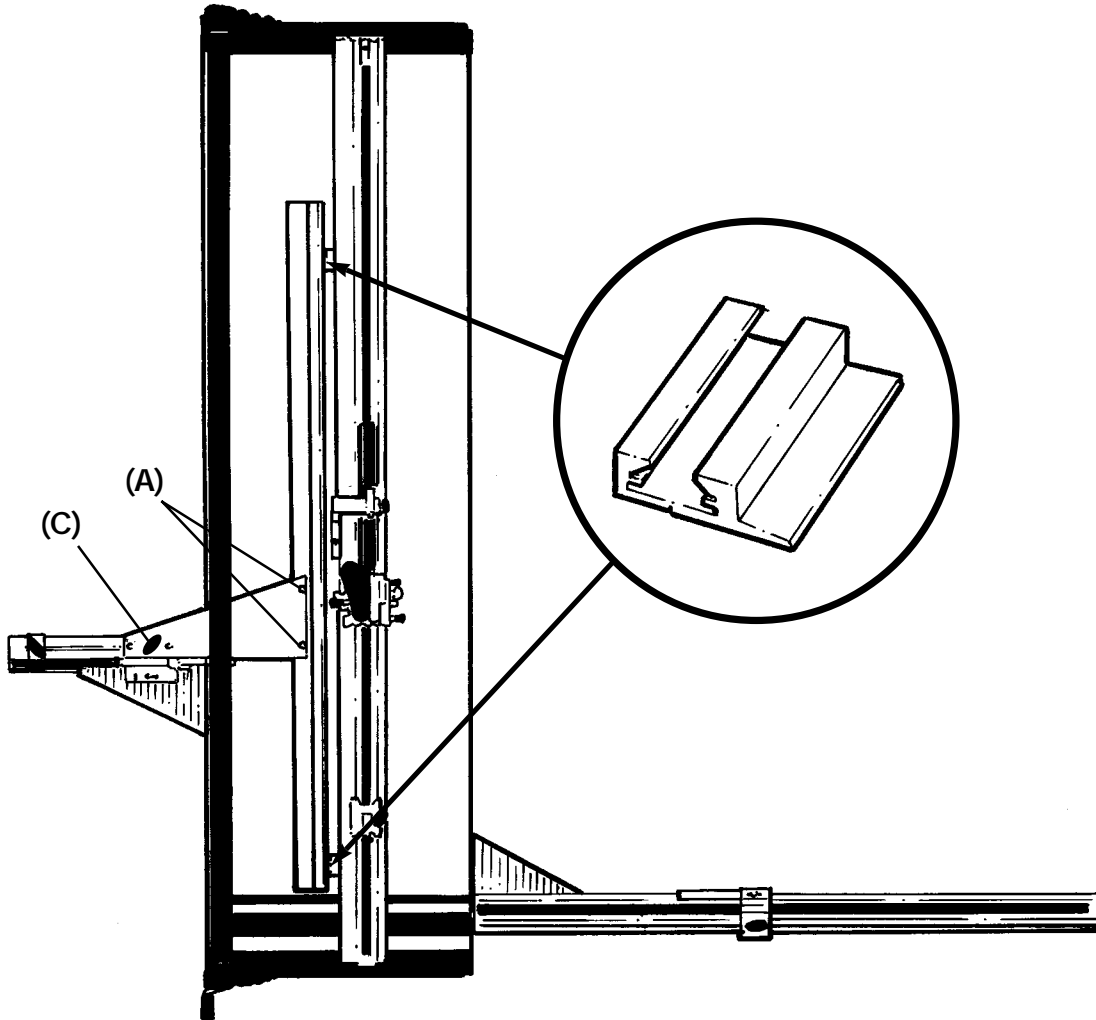

English

- THE ALIGNMENT OF THE MATGUIDE T-Bar with the Cutterbar is checked using the two spacers provided.

① Place the thin edge of the spacers under the Cutterbar, one near the top of the Matguide T-Bar and the other near the bottom.

Move the Matguide T-Bar across to touch both spacers and clamp the wingbolt (C).

If both spacers do not touch the Matguide T-Bar loosen the two Alignment Adjustment Screws (A).

Release the wingbolt (C) and move the Matguide T-Bar to the right touching the Matguide T-Bar on both spacers.

Tighten the wingbolt (C), gently tighten the two Alignment Screws (A), check the spacers now contact the Matguide T-Bar.

KEY: ② Matguide T-Bar ⑫ Cutterbar

Removing the Start of Cut Rule

You will need

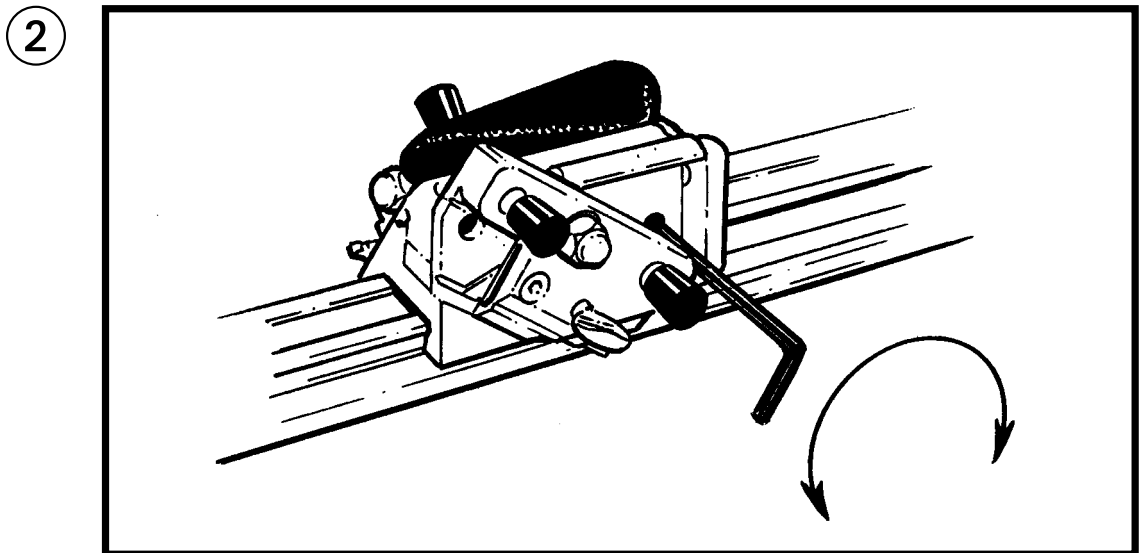
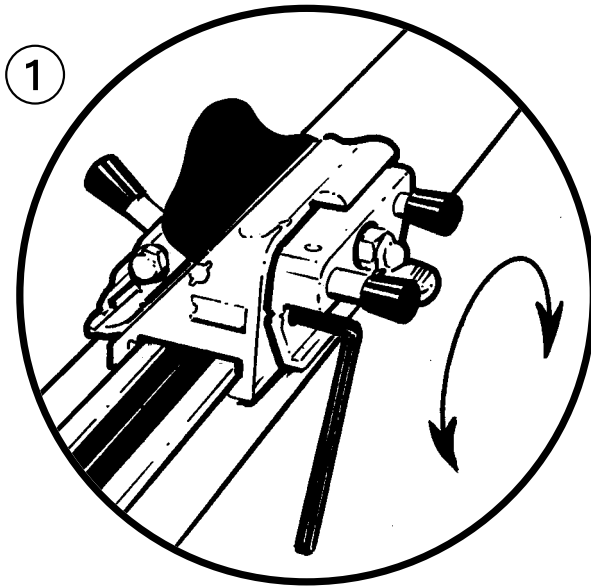

English

■ REMOVING THE START OF CUT RULE

- ① Loosen screw with 3mm hexagon wrench.
- ② Set the Vertical Blade Holder in the down position and loosen the second screw.

Remove the rule from the end of the Cutter Head.

If the machine is to be used without the Start of Cut Rule for any reason adjust both screws inwards to ensure they do not interfere with the Vertical Blade Holder.

You will
need



■ ADJUSTING THE CUTTER HEAD SLIDE BEARINGS

The bearings which control the sliding motion of the Ultimat Gold cutting head are machined from a remarkable material called Ultra High Molecular Weight Polyfine and they will never wear out. As the bearings settle into position you may wish to adjust them to eliminate side play from the sliding head as follows:-

- ① Remove the slip sheet to allow the cutter bar to lay flat on the machine base.
- ② Place the 2mm hexagon wrench in the front bearing adjustment screw (a) and turn clockwise by small increments (1/16th of a turn) sliding the head each time to check for free running.
- ③ When the head slides less easily turn the adjustment screw back counter-clockwise by one small increment or two to restore free running.
- ④ Repeat steps 2 & 3 on the back bearing adjustment (b) first rotating the bevel blade holder to gain access to the head of the adjustment screw.

NOTE

It is not necessary to remove the head for cleaning and once the bearings are adjusted to your preference you may never have to do it again.

6.1 Cutting techniques 6.1

Cutting Unequal Margins

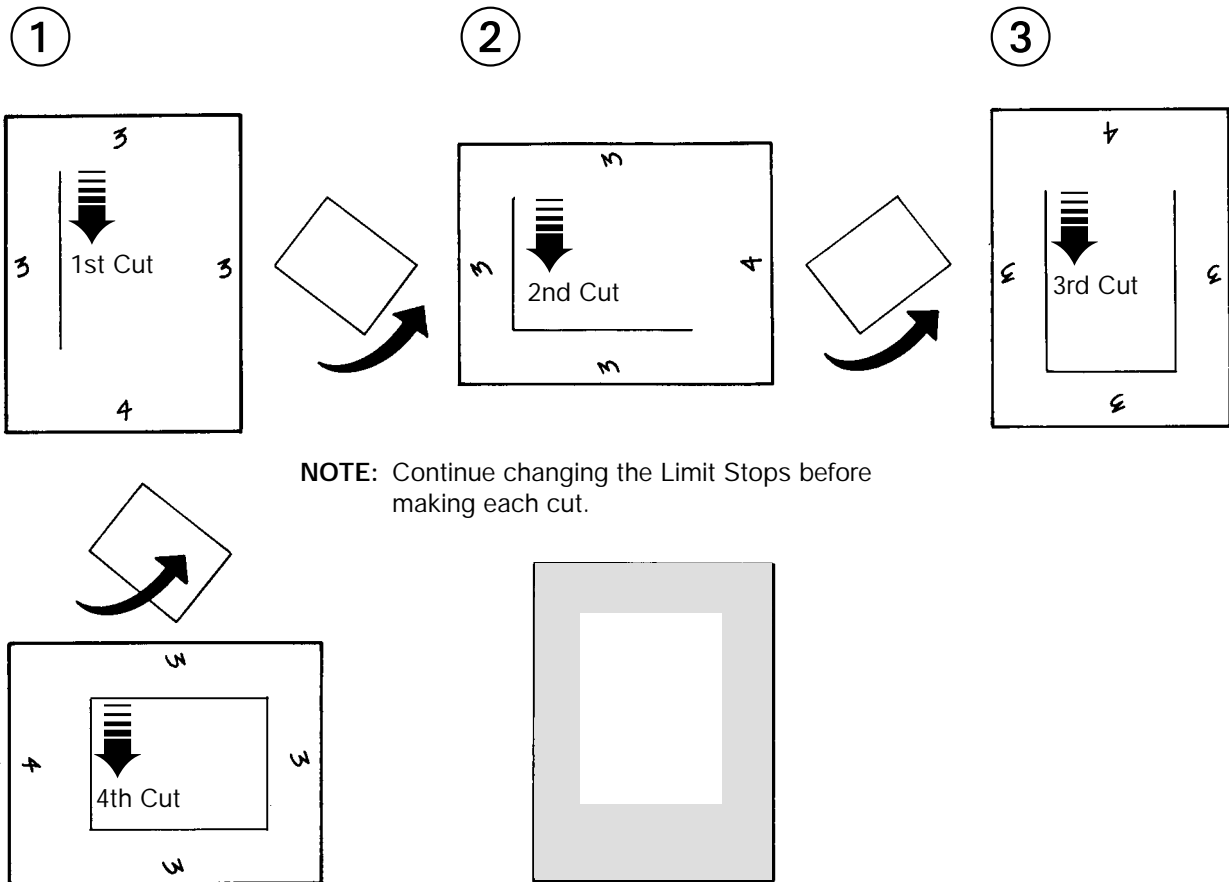

English

■ UNEQUAL MARGINS - Cutting a Mat with UNEQUAL MARGINS, for example 3,3,3 & 4.

Mark the back of the Mat with margin widths on each of the four edges as shown.

Place the Mat under the Cutterbar.

- ① Set the Matguide Limit Stop (blue) to the size shown on the left hand edge of the Mat (to 3 in this case).
Set the Start of Cut Limit Stop (green) to the size shown on the top of the Mat (to 3 in this case).
Set the End of Cut Limit Stop (red) to the size shown on the bottom of the Mat (to 4 in this case).
Make the first cut - turn the mat 90 degrees counter-clock wise .
- ② Set red stop to 3
Make a second cut - Turn the mat 90 degrees counter-clock wise.
- ③ Set green stop to 4
Make a third cut - Turn the mat 90 degrees counter-clock wise.
- ④ Set green stop to 3
Set blue stop to 4
Make the last cut.

Refer to 'Additional Matguide fittings' when cutting large quantities of Unequal Margin mats.

6.2 Cutting techniques 6.2

Cutting a V-Groove

You will need

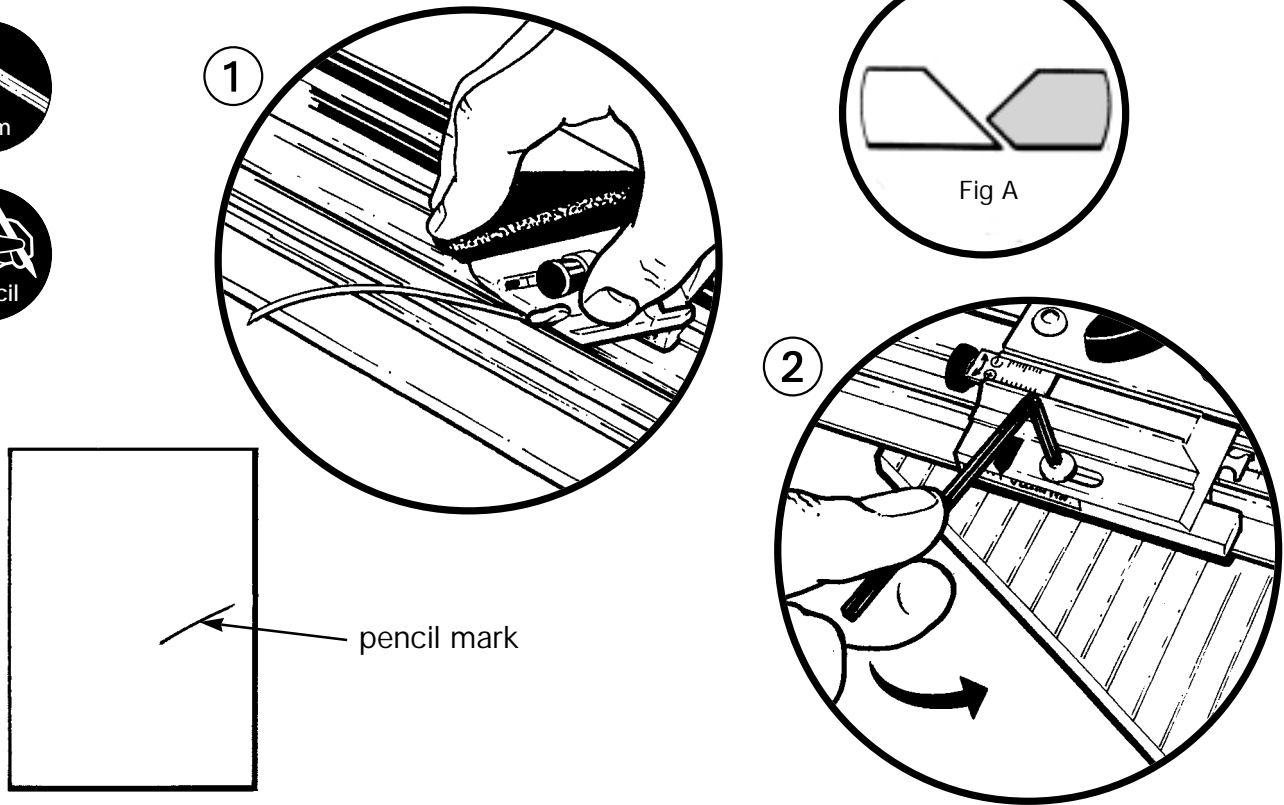

English

■ CUTTING A V-GROOVE

Lightly mark the back of the mat board with a pencil and then cut a Mat.

Remove the Mat and fallout and retain both.

Remove Slip Mat.

Set the Matguide forward as far as the V-Groove Stop permits.

Place the fallout (**coloured face up**) under the Cutterbar against the Matguide T-Bar.

- ① Fully depress the blade and draw it through the card.

Take care to remove the trimming.

Repeat on the remaining three edges of the fallout.

Place the fallout face down and position the Mat on it using the light pencil mark as a guide to place the pieces back correctly.

Tape the mount and the fallout together along the cut lines.

NOTE : Use thin tape or the thickness could upset the blade depth.

Take the assembled Mat Board and cut a Mat inside the V-Groove in the normal way.

■ CHANGING THE V-GROOVE WIDTH

- ② Release the dome socket screw using the 3mm hexagon wrench to release the V-Groove Stop. Using scrap fallouts, experiment with different settings until a new width of cut has been selected.

To widen and deepen the V-groove move Matguide T-Bar slightly away from the Cutterbar. Moving the matguide T-Bar closer to the Cutterbar will make the groove thinner and less deep. Too deep and the cut will fray and discolour in the centre and so part of the original bevel must remain on the fallout [fig A]

When you have selected the desired width, without moving the Matguide T-Bar, slide the V-Groove stop until it touches the side of the Base of the machine and tighten the dome locking screw..

KEY: ② Matguide T-Bar ⑤ Base ⑫ Cutterbar ⑬ V-Groove stop

6.3 Cutting techniques 6.3

Cutting Offset Corner Mats

English

Set the Limit Stops to the dimensions in the table below and make each set of cuts in the normal way. When cutting stepped or offset mats superior results can be obtained if the blade is lifted and then re-inserted in the centre of the mat at certain times during the cutting sequence. If you follow the examples below they will give you that sequence - it will save time and avoid errors.

■ **OFFSET CORNER MATS** - To cut at offset corner Mat 2 sets of 4 cuts are made.

Only 2 dimensions are required.

Set the Matguide Limit Stop (blue) to 3.

Set the Start of Cut Limit Stop (green) to 4.

Set the End of Cut Limit Stop (red) to 4.

Cut all four sides as for a normal Mat.

Set the Matguide Limit Stop (blue) to 4.

Set the Start of Cut Limit Stop (green) to 3.

Set the End of Cut Limit Stop (red) to 3.

Cut all four sides but this time remove and then re-insert the blade at approximately the middle of 'all four cuts - the centre fallout will then be in one piece.

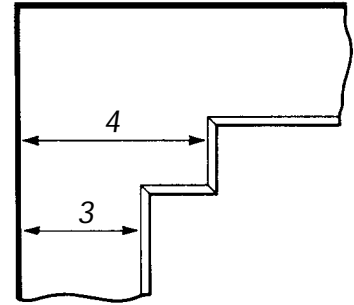

■ **DOUBLE OFFSET CORNER MATS**

- ① Set the Limit Stops to the dimensions in the table below. On the FIRST SEQUENCE and LAST SEQUENCE of cuts - remove and re-insert the blade at approximately the middle of all four cuts.

	Set Mat Guide to: (blue)	Set Start of Cut to: (green)	Set End of Cut to: (red)
1st set of cuts	3.5	3.5	3.5
2nd set of cuts	3.0	5.0	5.0
3rd set of cuts	5.0	3.0	3.0

- Lift blade

- Lift blade

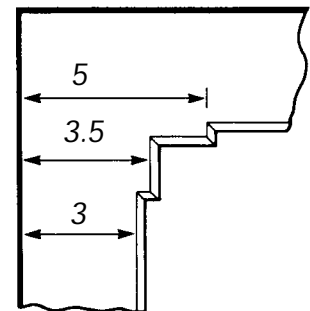

①

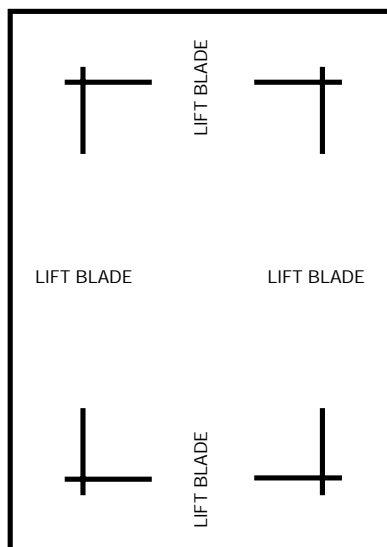

1st Set of Cuts

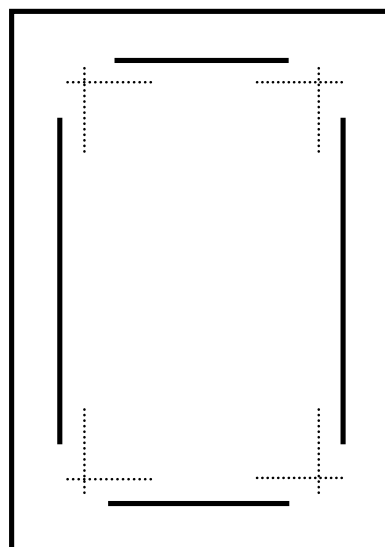

2nd Set of Cuts

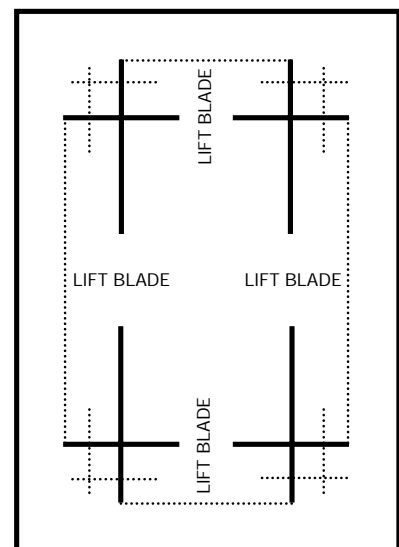

3rd Set of Cuts

KEY: ⑥ Start of Cut Limit Stop ⑩ End of Cut Limit Stop ⑮ Matguide Limit Stop

You will
need



Cutting Multiple openings & Title boxes

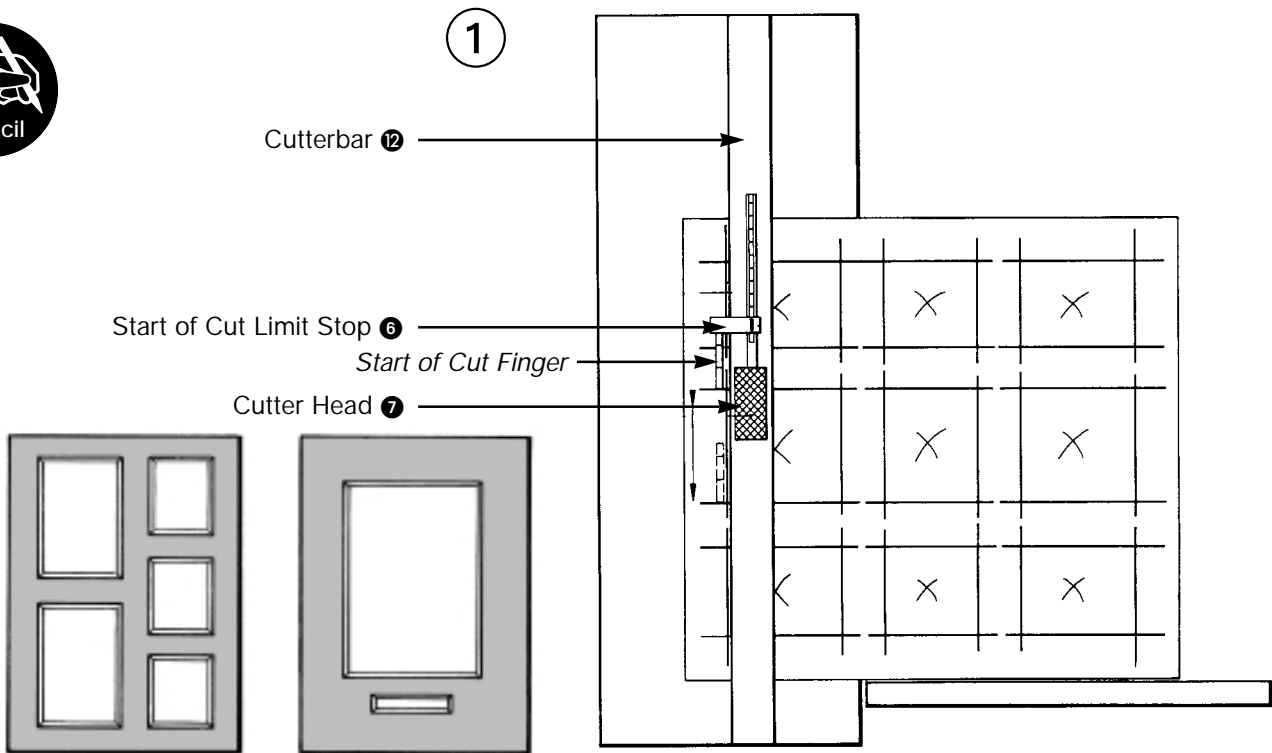

English

■ CUTTING MULTIPLE OPENINGS AND TITLE BOXES

The Start of Cut (green) Limit Stop can be used to great advantage after just a little practice to accurately cut multiple openings beyond the normal scope of the Stops.

Pencil mark the back of the Mat Board with the required layout and place an **X** in each aperture to be cut. If the **X** of the aperture to be cut is under or to the right of the cutter bar then the bevel will not be accidentally cut in the wrong direction.

- ① Place the Mat Board under the Cutterbar so the bevel blade cuts along the pencil line.
Set the Start of Cut (green) Limit Stop to zero.
Depress the Start of Cut Finger and move the Cutter Head until the tip of the finger reaches the horizontal line at the beginning of a marked aperture.
Insert the bevel blade fully.
Release the Start of Cut Finger.
Cut until the depressed tip of the Start of Cut Finger reaches the horizontal line at the end of the marked aperture.
Repeat until all the apertures are complete.

KEY: ⑥ Start of Cut Limit Stop ⑦ Cutter Head ⑫ Cutterbar

7.1 Optional accessories 7.1

English

- Clip on Base and matguide extension for controlling a cut up to 75cm (30") away from the matguide. Increases effective base width to 100cm (39").
- Clip on Base extension arms to increase the effective width of the base to 100cm (39") to hold large boards flat and square. Used with the matguide extension the effective base width is increased to 160cm (63").
- Three piece Multi angle tool set for creative matcutting in many styles and shapes.
- Space saving wall mounting kit with built in vertical storage feature.

FAULT	CAUSES AND SUGGESTIONS	FAULT	CAUSES AND SUGGESTIONS
Frayed mount surface	Change blade Replace slipmat	Blade not cutting through consistently	Change blade Adjust blade depth Avoid any pressure on handle
Over or undercuts in some corners only	Matboard out of square Apply even hand pressure on cutter head	Erratic cutter head movement	Clean and lubricate cutter bar as per instructions
Machine starts to undercut without apparent changes	Matboard not the same texture Worn slip mat Change the blade Check under cutter bar for tape or offcuts Adjust for any adhesive tape thickness on the mat	Cut line not straight	Change blade Uneven hand pressure on bevel blade holder
Distortions at start of cut (Hooking)	Blade set too deep Change blade (worn) Avoid any hand pressure on handle Sideplay in cutter head - adjust Do not release the start of cut finger until the blade has fully penetrated the mat	Matboard not cutting through in centre of the cut	Apply no pressure to the handle Blade too thin for the mat <i>[see Blade types]</i> Avoid putting any pressure on the handle when cutting as it causes the cutter bar to curve up in the middle which affects the line of cut and clamping
Blade will not eject	Push the blade forward and try again	Matboard not clamping	Check clearance between the handle and the lift hold. Check rubber grip strip under cutter bar. Check under cutter bar for tape or offcuts
Blade not cutting through on the last cut	Worn blade		

IMPORTANT At the first sign of any cutting defect change the blade.
Do not adjust blade depth before changing the blade.

■ MAINTENANCE

Your matcutter is a precision made machine and will give many years of accurate and reliable service if you follow these few simple steps.

Keep all liquids (including tea and coffee) away from the machine - spillages spoil the machines performance and Mats cut upon it.

Dust/vacuum daily, for stubborn stains use detergent/ water mix firstly applied to a cloth.

Cover the machine overnight with a plastic or fabric sheet.

If you need to move the machine away from the bench when it is not in use, store it either flat or if you have to stand it on end fasten the end of cut stop and use a strong elastic band to fix the cutter head to it. Then stand it on its top end leaning against a stable support.

Please note:- Standing the matcutter on end should be avoided if possible but, providing it is done carefully no harm will come to it.

In the event of heavy soiling on any part of the machine solvents can be used for cleaning but:-

Apply the solvent to a cloth and not directly on the matcutter.

Read and comply with the solvents safety instructions.

Do not allow solvent to come in contact with any printed or plastic parts of the machine.

■ LUBRICATION of the cutter bar should not be necessary if the matcutter is kept clean.

However, should you wish to, use silicone lubricant preferably applied with a sponge pad or a spray applied to a cloth first. Follow the health instructions on spray cans.

DO NOT USE OIL, GREASE OR MULTI-PURPOSE PENETRATING OIL ON THE CUTTER BAR.

Oil can be used lightly on the lift and hold, pivot lift arm hinges and cutter bar pivots.